

CL 50 1 speed - 4 Discs

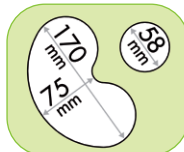

| | | |
|----------|------------------------------------|------------------|
| D | Number of meals per service | 50 to 400 |
| | Theoretical output per hour* | up to 500 kg/h |

A SALES FEATURES
 The 1-speed CL 50 Vegetable Preparation Machine is ideal for slicing, ripplecutting, grating, dicing, shredding and making french fries from all types of fruit and vegetables, as well as grating cheese.

B TECHNICAL FEATURES
 The 1-speed CL 50 Vegetable Preparation Machine – Single-phase 240V/50/1. Power 550 W. Speed 375 rpm. Equipped with a magnetic safety system, motor brake and lever-activated auto restart. This Veg. Prep. Machine has a lateral ejection facility and is equipped with 2 hoppers: 1 large capacity hopper diameter: 139 cm²; loading volume - 2.2 litres, and 1 cylindrical hopper: Ø 58 mm and/or Ø 39 mm. Metal vegetable bowl and lid. D-Clean Kit. Suitable for 50 to 400 meals per service. 4 discs included: 2 mm slicer, 4 mm slicer, 2 mm grater, 4x4 mm julienne. Large range of 50 Mineral+ discs available as option: easy cleaning, dishwasher resistant. Select your options at the back page **F** part.

| C TECHNICAL DATA | | |
|------------------------------|------------------------------|------------------|
| Output power | 550 Watts | |
| Electrical data | Single-phase - plug included | |
| Speed | 375 rpm | |
| Dimensions (WxDxH) | 380 x 305 x 595 mm | |
| Rate of recyclability | 95 % | |
| Net weight | 19.8 kg | |
| Supply | Amperage | Reference |
| 240V/50/1 | 5.7 | 1845 |

STANDARDS
 EN 12100-1 and 2 - 2004, EN 60204- 1 - 2006, EN 1678 - 1998, EN 60529-2000: IP 55, IP 34.



E PRODUCT FEATURES / BENEFITS

MOTOR BASE

- Industrial induction motor for intensive use.
- Power - 550 Watts.
- Motor base in high resistant composite material.
- Stainless steel motor shaft.
- Magnetic safety system with motor brake.
- Speed - 375 rpm

VEGETABLE PREPARATION FUNCTION

- Vegetable Preparation Machine equipped with 2 hoppers:
 - 1 semi-circular hopper to chop bulky vegetables such as cabbage and celeriac.
 - 1 cylindrical hopper for long, delicate vegetables. The Exactitube pusher can be used to reduce the diameter of the hopper for cutting up small ingredients.
- Removable lid.
- Reversible ejector disc for processing delicate produce.
- Lateral ejection facility for space-saving and greater user comfort, and accommodates 150 mm high gastronorm pans
- Lever-activated auto restart (by the pusher)
- Vertical pusher pressure exerted on vegetables to ensure uniform cuts.
- Large range of 50 Mineral+ discs available as option: easy cleaning, dishwasher resistant.
- 4 discs included: 2 mm slicer, 4 mm slicer, 2 mm grater, 4x4 mm julienne.
- Stainless steel blades on slicing discs, combs on Julienne discs and grating discs are removable.
- D-Clean Kit to facilitate cleaning of dicing grids.

MASHED POTATO FUNCTION

- Optional: a simple way of making large quantities, up to 10 kg, of fresh mashed potato in just 2 minutes

* Depend on the type of the hopper used, the choice of the cut and the organisation of the workstation.

CL 50 1 speed - 4 Discs

F OPTIONAL ACCESSORIES

- EasyClean Xpress 8x8mm - Ref. 49305
- EasyClean Xpress 10x10mm - Ref. 49309
- EasyClean Xpress 12x12mm - Ref. 49313
- EasyClean Xpress 14x14mm - Ref. 49314
- Wall 8-disc holder - Ref.107812
- 3mm Mashed potato attachment - Ref. 28207
- 6mm Mashed potato attachment - Ref. 28209
- EasyStacker - Ref. 49332
- EasyLoader - Ref. 49323
- 6x6 mm French Fry attachment - Ref. 49324
- 8x8 mm French Fry attachment - Ref. 49325
- 8x16 mm French Fry attachment - Ref. 49326
- 10x10 mm French Fry attachment - Ref. 49327
- 10x16 mm French Fry attachment - Ref. 49328

SUGGESTED PACKS OF DISCS

Restaurants pack of 8 discs
Ref 1933
Slicers: 2mm, 5mm; Grater: 2mm; Julienne: 3 x 3mm; Dicing Set: 10 x 10mm (2 discs); Chipping Set: 10 x 10mm (2 discs).

Cultural market pack of 7 discs
Ref 1943
Slicers: 2mm, 5mm; Grater: 2mm; Julienne: 3 x 3mm, 4 x 4mm; Dicing Set: 10 x 10mm (2 Discs).



SLICERS

| | |
|----------------------|--------|
| 0.6 mm | 28166W |
| 0.8 mm | 28069W |
| 1 mm | 28062W |
| 2 mm | 28063W |
| 3 mm | 28064W |
| 4 mm | 28004W |
| 5 mm | 28065W |
| 6 mm | 28196W |
| 8 mm | 28066W |
| 10 mm | 28067W |
| 14 mm | 28068W |
| Cooked potatoes 4 mm | 27244W |
| Cooked potatoes 6 mm | 27245W |



RIPPLE CUT SLICERS

| | |
|------|--------|
| 2 mm | 27068W |
| 3 mm | 27069W |
| 5 mm | 27070W |



GRATERS

| | |
|------------------------|--------|
| 1.5 mm | 28056W |
| 2 mm | 28057W |
| 3 mm | 28058W |
| 4 mm | 28073W |
| 5 mm | 28059W |
| 7 mm | 28016W |
| 9 mm | 28060W |
| Parmesan | 28061W |
| Röstis potatoes | 27164W |
| Raw potatoes | 27219W |
| Horseradish paste 1 mm | 28055W |



JULIENNE

| | |
|------------|--------|
| 1x8 mm | 28172W |
| 1x26 mm | 28153W |
| 2x4 mm | 28072W |
| 2x6 mm | 27066W |
| 2x8 mm | 27067W |
| 2x10 mm | 28173W |
| 2x2 mm | 28051W |
| 2.5x2.5 mm | 28195W |
| 3x3 mm | 28101W |
| 4x4 mm | 28052W |
| 6x6 mm | 28053W |
| 8x8 mm | 28054W |

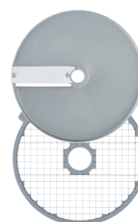

DICING EQUIPMENT

| | |
|--------------------|--------|
| 5x5x5 mm | 28110W |
| 8x8x8 mm | 28111W |
| 10x10x10 mm | 28112W |
| 12x12x12 mm | 28197W |
| 14x14x5 mm | 28181W |
| 14x14x10 mm | 28179W |
| 14x14x14 mm | 28113W |
| 20x20x20 mm | 28114W |
| 25x25x25 mm | 28115W |
| 50x70x25 mm salads | 28180W |



FRENCH FRY EQUIPMENT

| | |
|-------------------|--------|
| 6x6 mm attachment | 49324 |
| 8x8 mm | 28134W |
| 8x16 mm | 28159W |
| 10x10 mm | 28135W |
| 10x16 mm | 28158W |

G

DRAWINGS AND DIMENSIONS

Single phase - plug included

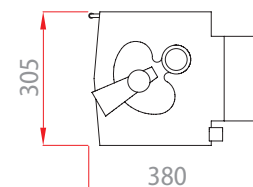
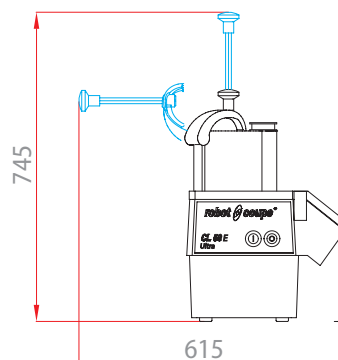
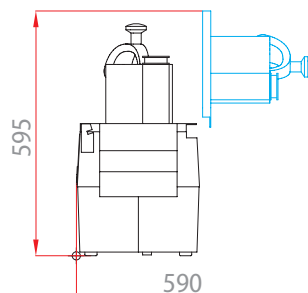
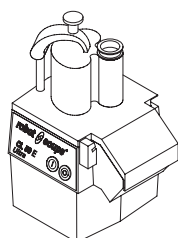

CL 50 - 1 speed



OPTIONAL
+
50
DISCS

10 Dicing
5 French fries

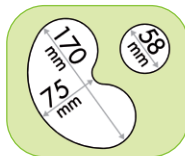

| | | |
|----------|-------------------------------------|-----------------------|
| D | Number of meals per service | 50 to 400 |
| | Theoretical output per hour* | up to 500 kg/h |

A SALES FEATURES

The 1-speed CL 50 Vegetable Preparation Machine is ideal for slicing, ripplecutting, grating, dicing, shredding and making french fries from all types of fruit and vegetables, as well as grating cheese.

B TECHNICAL FEATURES

The 1-speed CL 50 Vegetable Preparation Machine – Single-phase 230V/50/1. Power 550 W. Speed 375 rpm. Equipped with a magnetic safety system, motor brake and lever-activated auto restart. This Veg. Prep. Machine has a lateral ejection facility and is equipped with 2 hoppers: 1 large capacity hopper diameter: 139 cm²; loading volume - 2.2 litres, and 1 cylindrical hopper: Ø 58 mm and/or Ø 39 mm. Metal vegetable bowl and lid. D-Clean Kit. Suitable for 50 to 400 meals per service. No discs included. Large range of 50 Mineral+ discs available as option: easy cleaning, dishwasher resistant.

Select your options at the back page **F** part.

| C TECHNICAL DATA | | |
|------------------------------|------------------------------|------------------|
| Output power | 550 Watts | |
| Electrical data | Single-phase - plug included | |
| Speed | 375 rpm | |
| Dimensions (WxDxH) | 380 x 305 x 595 mm | |
| Rate of recyclability | 95 % | |
| Net weight | 19.8 kg | |
| Supply | Amperage | Reference |
| 230V/50/1 | 5.7 | 24443 |

STANDARDS
EN 12100-1 and 2 - 2004, EN 60204- 1 - 2006, EN 1678 - 1998, EN 60529-2000: IP 55, IP 34.



E PRODUCT FEATURES / BENEFITS

MOTOR BASE

- Industrial induction motor for intensive use.
- Power - 550 Watts.
- Motor base in high resistant composite material.
- Stainless steel motor shaft.
- Magnetic safety system with motor brake.
- Speed - 375 rpm

VEGETABLE PREPARATION FUNCTION

- Vegetable Preparation Machine equipped with 2 hoppers:
 - 1 semi-circular hopper to chop bulky vegetables such as cabbage and celeriac.
 - 1 cylindrical hopper for long, delicate vegetables. The Exactitube pusher can be used to reduce the diameter of the hopper for cutting up small ingredients.
- Removable lid.
- Reversible ejector disc for processing delicate produce.
- Lateral ejection facility for space-saving and greater user comfort, and accommodates 150 mm high gastronorm pans
- Lever-activated auto restart (by the pusher)
- Vertical pusher pressure exerted on vegetables to ensure uniform cuts.
- Large range of 50 Mineral+ discs available as option: easy cleaning, dishwasher resistant.
- No discs included.
- Stainless steel blades on slicing discs, combs on Julienne discs and grating discs are removable.
- D-Clean Kit to facilitate cleaning of dicing grids.

MASHED POTATO FUNCTION

- Optional: a simple way of making large quantities, up to 10 kg, of fresh mashed potato in just 2 minutes

* Depend on the type of the hopper used, the choice of the cut and the organisation of the workstation.

CL 50 - 1 speed

F OPTIONAL ACCESSORIES

- EasyClean Xpress 8x8mm - Ref. 49305
- EasyClean Xpress 10x10mm - Ref. 49309
- EasyClean Xpress 12x12mm - Ref. 49313
- EasyClean Xpress 14x14mm - Ref. 49314
- Wall 8-disc holder - Ref.107812
- 3mm Mashed potato attachment - Ref. 28207
- 6mm Mashed potato attachment - Ref. 28209
- EasyStacker - Ref. 49332
- EasyLoader - Ref. 49323
- 6x6 mm French Fry attachment - Ref. 49324
- 8x8 mm French Fry attachment - Ref. 49325
- 8x16 mm French Fry attachment - Ref. 49326
- 10x10 mm French Fry attachment - Ref. 49327
- 10x16 mm French Fry attachment - Ref. 49328

SUGGESTED PACKS OF DISCS

Restaurants pack of 8 discs
Ref 1933
Slicers: 2mm, 5mm; Grater: 2mm; Julienne: 3 x 3mm; Dicing Set: 10 x 10mm (2 discs); Chipping Set: 10 x 10mm (2 discs).

Cultural market pack of 7 discs
Ref 1943
Slicers: 2mm, 5mm; Grater: 2mm; Julienne: 3 x 3mm, 4 x 4mm; Dicing Set: 10 x 10mm (2 Discs).



SLICERS

| | |
|----------------------|--------|
| 0.6 mm | 28166W |
| 0.8 mm | 28069W |
| 1 mm | 28062W |
| 2 mm | 28063W |
| 3 mm | 28064W |
| 4 mm | 28004W |
| 5 mm | 28065W |
| 6 mm | 28196W |
| 8 mm | 28066W |
| 10 mm | 28067W |
| 14 mm | 28068W |
| Cooked potatoes 4 mm | 27244W |
| Cooked potatoes 6 mm | 27245W |



RIPPLE CUT SLICERS

| | |
|------|--------|
| 2 mm | 27068W |
| 3 mm | 27069W |
| 5 mm | 27070W |



GRATERS

| | |
|------------------------|--------|
| 1.5 mm | 28056W |
| 2 mm | 28057W |
| 3 mm | 28058W |
| 4 mm | 28073W |
| 5 mm | 28059W |
| 7 mm | 28016W |
| 9 mm | 28060W |
| Parmesan | 28061W |
| Röstis potatoes | 27164W |
| Raw potatoes | 27219W |
| Horseradish paste 1 mm | 28055W |



JULIENNE

| | |
|------------|--------|
| 1x8 mm | 28172W |
| 1x26 mm | 28153W |
| 2x4 mm | 28072W |
| 2x6 mm | 27066W |
| 2x8 mm | 27067W |
| 2x10 mm | 28173W |
| 2x2 mm | 28051W |
| 2.5x2.5 mm | 28195W |
| 3x3 mm | 28101W |
| 4x4 mm | 28052W |
| 6x6 mm | 28053W |
| 8x8 mm | 28054W |

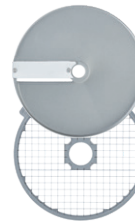

DICING EQUIPMENT

| | |
|--------------------|--------|
| 5x5x5 mm | 28110W |
| 8x8x8 mm | 28111W |
| 10x10x10 mm | 28112W |
| 12x12x12 mm | 28197W |
| 14x14x5 mm | 28181W |
| 14x14x10 mm | 28179W |
| 14x14x14 mm | 28113W |
| 20x20x20 mm | 28114W |
| 25x25x25 mm | 28115W |
| 50x70x25 mm salads | 28180W |



FRENCH FRY EQUIPMENT

| | |
|-------------------|--------|
| 6x6 mm attachment | 49324 |
| 8x8 mm | 28134W |
| 8x16 mm | 28159W |
| 10x10 mm | 28135W |
| 10x16 mm | 28158W |

G

DRAWINGS AND DIMENSIONS

Single phase - plug included

