

# robot coupe<sup>®</sup>

New  
Register  
your product  
on line



**R 502 G • R 502 V.V. G • R 752 • R 752 V.V.**

# www.robot-coupe.com

## @ Register your product on line

The screenshot displays the Robot-Coupe website's support section. At the top, the navigation bar includes the company logo, links for 'The company', 'Contact us', and 'Restricted Area', and a 'Select your country...' dropdown. Below this, a menu contains 'CATALOGUE', 'SELECTION GUIDE', 'LEAFLETS', 'VIDEOS', 'OUR SUPPORT', and a search bar. The main heading is 'SUPPORT'. The page is divided into two columns. The left column, titled 'Register your product online', provides instructions and a list of required information: 'Product serial number' and 'Purchase date'. A button labeled 'Register my product now' is at the bottom of this column. The right column, titled 'Access the Robot-Coupe after-sales service', features an 'Authentication' form with fields for 'Identifiant', 'Mot de passe', and 'Email', along with a 'Mot de passe perdu' link. A button labeled 'Access the Robot-Coupe after-sales service' is at the bottom of this column.

# robot coupe®

## EU Declaration of Conformity

**Robot-Coupe® SNC** declares that all the machines subject of these original instructions, as well as their accessories and their packaging, comply with:

- the essential requirements of the following European directives and with the corresponding national regulations :
  - Directive "Machinery" **2006/42/EC**,
  - Directive "Low Voltage" **2014/35/EU**,
  - Directive "Electromagnetic Compatibility" **2014/30/EU**,
  - Directive "Reduction of Hazardous Substances in Electrical Equipment" (RoHS) **2011/65/EU**,
  - Directive "Waste Electrical and Electronic Equipment" (WEEE) **2012/19/EU**,
- Regulation (EC) No **1907/2006** (latest consolidated version) «concerning the Registration, Evaluation, Authorisation and Restriction of Chemicals (REACH)» and as such, no product, accessory and their packaging sold by Robot-Coupe® SNC, contains any substance on the European Chemical Agency (ECHA) candidate list and considered of very high concern.
- Regulation (EC) No **1935/2004** «Materials and articles intended to come into contact with food» modified by regulation (EC) No 596/2009.
- Regulation (EC) No **2023/2006** «Good manufacturing practice for materials and articles intended to come into contact with food».
- Regulation (EU) No **10/2011** «Plastic materials and articles intended to come into contact with food», as well as all relevant (EU) regulations which modify, correct and/or rectify it, as at the date of this declaration, the regulations (EU) No 1282/2011, 1183/2012, 202/2014, 865/2014, 2015/174, 2016/1416, 2017/752, 2018/79, 2018/213, 2018/831 and 2019/37.
- the provisions of the following harmonized European standards and the standards specifying the safety and hygiene requirements:
  - **EN ISO 12100:2010** Safety of machinery – General principles for design,
  - **EN 60204-1:2006** Safety of machinery – Electrical equipment of machines,
  - **EN 60529** Degrees of protection provided by enclosures (IP Code):
    - IP 55 for the electric controls,
    - IP 34 for the other parts of the machine,
- and according to the category of the apparatus, with the provisions of the following harmonized European standards specifying the safety and hygiene requirements:
  - **EN 454** ..... Planetary Mixers,
  - **EN 1678** ..... Vegetable Cutting Machines (and Juice Extractors),
  - **EN 12852** ..... Food Processors and Blenders,
  - **EN 12853** ..... Hand-Held Blenders and Whisks (Power Mixers),
  - **EN 13208** ..... Vegetable Peelers,
  - **EN 13621** ..... Salad Dryers,
  - **EN 14655** ..... Baguette Slicers.

"R019"

Montceau-en-Bourgogne, on March 1<sup>st</sup>, 2019

Jean-Marie LOZANO  
Director of Industrial Operations



# SUMMARY

## WARRANTY

## IMPORTANT WARNING

## INTRODUCTION TO YOUR NEW R 502 G • R 502 V.V. G • R 752 • R 752 V.V. BOWL CUTTER / VEGETABLE PREPARATION

## SWITCHING ON THE MACHINE

- Advices on electrical connections
- Control panel
- Timer

## ASSEMBLY

- Bowl cutter attachment
- Vegetable preparation attachment

## USES & EXAMPLES

- Bowl cutter attachment
- Vegetable preparation attachment

## OPTIONS

## CLEANING

- Motor base
- Bowl cutter attachment
- Scraper arm
- Blade
- Vegetable preparation attachment

## MAINTENANCE

- Blade
- Motor seal
- Scraper arm
- Blades, combs and grater

## TECHNICAL SPECIFICATIONS

- Weight
- Dimensions
- Working height
- Noise level
- Electrical data

## SAFETY

## STANDARDS

## TECHNICAL DATA

- Electrical and wiring diagrams

# ROBOT-COUPE S.N.C., LIMITED WARRANTY

Your new ROBOT-COUPE appliance is warranted to the original buyer for a period of one year from the date of sale if you bought it from ROBOT-COUPE S.N.C.

If you bought your ROBOT-COUPE product from a distributor your product is covered by your distributor's warranty (Please check with your distributor terms and conditions of the warranty).

The ROBOT-COUPE S.N.C. limited warranty is against defects in material and/or workmanship.

## THE FOLLOWING ARE NOT COVERED BY THE ROBOT-COUPE S.N.C. WARRANTY:

**1** - Damage caused by abuse, misuse, dropping, or other similar damage caused by or resulting from failure to follow assembly, operating, cleaning, user maintenance or storage instructions.

**2** - Labour to sharpen and/ or replacements for blades which have become blunt, chipped or worn after a normal or excessive period of use.

**3** - Materials or labour to replace or repair scratched, stained, chipped, pitted, dented or discoloured surfaces, blades, knives, attachments or accessories.

**4** - Any alteration, addition or repair that has not been carried out by the company or an approved service agency.

**5** - Transportation of the appliance to or from an approved service agency.

**6** - Labour charges to install or test new attachments or accessories (i.e., bowls, discs, blades, attachments) which have been arbitrarily replaced.

**7** - The cost of changing direction-of-rotation of electric motors (Installer is responsible).

**8** - SHIPPING DAMAGES. Visible and latent defects are the responsibility of the freight carrier. The consignee must inform the carrier and consignor immediately, or upon discovery in the case of latent defects.

KEEP ALL ORIGINAL CONTAINERS AND PACKING MATERIALS FOR CARRIER INSPECTION.

Neither ROBOT-COUPE S.N.C. nor its affiliated companies or any of its distributors, directors, agents, employees, or insurers will be liable for indirect damage, losses, or expenses linked to the appliance or the inability to use it.

The ROBOT-COUPE S.N.C. warranty is given expressly and in lieu of all other warranties, expressed or implied, for merchantability and for fitness toward a particular purpose and constitutes the only warranty made by ROBOT-COUPE S.N.C. France.

# RECOMMENDATIONS CONCERNING THE INSTALLATION OF VARIABLE-SPEED APPLIANCES AND PERSONAL SAFETY

These recommendations apply to machines equipped with an induction motor and a single-phase wobbulator.

## NB :

- The electrical circuit and the protective devices must comply with national regulations.
- The machine must be wired in by a qualified electrician

## Protecting your appliance

- Like all electronic devices, wobblators include components that are sensitive to electrostatic discharges (ESDs). Before conducting any work on these wobblators, technicians must therefore rid themselves of electrostatic charges.
- The machine must be disconnected from the mains supply before any internal connection operations are carried out.
- Repeatedly switching on the appliance will cause the wobbulator to overload and may result in its destruction. After the machine has been switched off, you must wait for 3 minutes before switching it back on again.

## Wiring

- The appliance requires single-phase current as far as the wobbulator, which turns the latter into variable-speed three-phase current to supply the motor.

- You must connect the machine to a 200 - 240 V / 50 or 60 Hz single-phase alternating current supply with an earthed socket. A higher voltage will destroy the wobbulator.
- The earthed socket ensures operator safety.

## Circuit interrupters ensuring user safety

Ground fault circuit interrupters (GFCIs) intended for variable-speed appliances need to be selected with great care in order to ensure operator safety. GFCIs may be sensitive to alternating current (type AC), impulse current (type A) or all currents (type B).

**Danger !** Wobblators feature a bridge-connected rectifier of the mains supply voltage. For this reason, in the event of an earth contact, a continuous fault current may fail to trip a differential circuit breaker that is only sensitive to alternating current (type AC).

As the appliance has a single-phase supply, it is therefore advisable to use a GFCI that is sensitive to impulse current (type A), identified by the following symbol : .

**Caution :** these GFCIs may go under different names, according to the manufacturer.

Appliances with wobblators produce a fault current on the earth wire. This current may be sufficient to trip the differential circuit breaker unnecessarily. This may occur if :

- Several variable-speed appliances are connected to the same GFCI.

- The appliance produces a fault current that is above the GFCI's actual trip threshold.

**Caution :** As there are manufacturing tolerances, the actual trip threshold of a GFCI will be between 50% and 100% of its theoretical nominal threshold. Should a problem arise, measure the fault current and the GFCI's actual trip threshold.

You can begin by consulting the characteristics of your appliance in the table below:

Appliance	Mains supply	Conductor Cross-section (mm <sup>2</sup> )	GFCI (Ph + N)	
			Gauge (A)	Threshold (mA)
R 502 V.V. R 752 V.V.	200 - 240V 50 or 60 Hz single-phase	2,5	B 20 A	≥ 30

# IMPORTANT WARNING



**WARNING:** In order to limit accidents such as electric shocks or personal injury, and in order to limit material damage due to misuse of the appliance, please read these instructions carefully and follow them strictly. Reading the operating instructions will help you get to know your appliance and enable you to use the equipment correctly. Please read these instructions in their entirety and make sure that anyone else who may use the appliance also reads them beforehand. Our equipment is designed for professional use and must not be used by children under any circumstances.

## UNPACKING

- Carefully remove the equipment from the packaging and take out all the boxes or packets containing attachments or specific items.
- **WARNING** - some of the tools are very sharp e.g. blade, discs...

## INSTALLATION

- We recommend you install your machine on a perfectly stable solid base.

## CONNECTION

- Always check that your mains supply corresponds to that indicated on the rating plate on the motor unit and that it can take the amperage.
- The machine must be earthed.
- With the three-phased version, always check that the blade rotates in an anti-clockwise direction.

## HANDLING

- Always take care when handling the blades or discs - they are very sharp.

## ASSEMBLY PROCEDURES

- Follow the various assembly procedures carefully (see page 8) and make sure that all the attachments are correctly positioned.

## USE

- Never try to override the locking and safety systems.
- Never introduce any object into the container where the food is being processed.
- Never push the ingredients down with your hand.
- Do not overload the appliance.
- Never switch the appliance on while it is empty.

## CLEANING

- As a precaution, always unplug your appliance before cleaning it.
- Always clean the appliance and its attachments at the end of each cycle.
- Never place the motor unit in water.
- For parts made of aluminum alloys, use cleaning fluids suitable for aluminum.

- For plastic parts, do not use detergents that are too alkaline (i.e., containing too much caustic soda or ammonia...).
- Robot-Coupe can in no way be held responsible for the user's failure to follow the basic rules of cleaning and hygiene.

## MAINTENANCE

- Before opening the motor housing, it is absolutely vital unplug the appliance.
- Check the seals and washers regularly and ensure that the safety devices are in good working order.
- It is particularly important to maintain and check the attachments since certain ingredients contain corrosive agents e.g. citric acid.
- Never operate the appliance if the power cord or plug has been damaged in any way or if the appliance fails to work properly or has been damaged in any way.
- Do not hesitate to contact your local Maintenance Department if something appears to be wrong.

## INTRODUCTION TO YOUR NEW BOWL CUTTER/VEGETABLE PREPARATION ATTACHMENT

**R 502 G • R 502 V.V. G •  
R 752 • R 752 V.V.**

The food processor is perfectly geared to professional needs. It can perform any number of tasks, which you will gradually discover as you use it. The food processor consists of a bowl cutter and vegetable preparation attachment. In cutter mode, this machine can be used to process meat, vegetables, fine stuffing, mousse, grinding, kneading, ... in less than 5 minutes for even the longest tasks.

In the vegetable preparation version, the device has a wide range of discs for slicing, grating, julienne, dicing and French fries.

Its numerous functions will open the door to a whole new culinary world.

Thanks to its simple design, all components requiring frequent handling for maintenance or cleaning can be fitted and removed in a trice.

To make things easier for you, this manual gives a breakdown of all the various fitting operations.

We place special emphasis on those actions which cause the machine to stop.

This manual contains important information designed to help the user get the most out of his or her bowl cutter/vegetable preparation device.

**We therefore recommend that you read it carefully before using your machine.**

We have also included a few examples to help you get the feel of your new machine and appreciate its numerous advantages.

## SWITCHING ON THE MACHINE

### • ADVICE ON ELECTRICAL CONNECTIONS

Before plugging in, check that your power supply corresponds to that indicated on the machine's identification plate.



## WARNING

**This appliance must be plugged into an earthed socket (risk of electrocution).**

### R 502 • R 752 Three phase

ROBOT-COUCPE appliances are fitted with the following types of motor:

- 230 x 400 V switchable / 50 Hz / 3
- 400 V / 50 Hz / 3
- 220 V / 60 Hz / 3
- 380 V / 60 Hz / 3

This machine is supplied with a cable to which you simply attach the appropriate electrical plug or isolator for your system. The cable has four wires, one earth wire, plus three phases wires.

### If you have a 4-pin plug:

- 1) Connect the green and yellow earth wire to the earth pin.
- 2) Connect the three other wires to the remaining pins.

**If you have more than 4 pins in the plug**, please note the ROBOT-COUCPE does not require a neutral wire.

**Switch on the empty machine, making sure that the blade is rotating properly in an anti-clockwise direction.**

On the lid a arrow marks the blade rotation directions. If the blade turns in a clockwise direction, swap over two wires.

If the blade turns in a clockwise direction, swap over two wires:

**GREEN YELLOW is the earth,  
DO NOT DISCONNECT**

Swap either :    the ❶ and the ❷  
                          the ❶ and the ❸  
                          the ❷ and the ❸

### R 502 V.V. • R 752 V.V. Single phase

The models are available with a single phase motor: + variable speed: 230 V / 50 - 60 Hz / 1

The standardized plug must be calibrated to a minimum of 16 amps and preferably 20 amps, if the appliance is used intensively.

### • ENERGY SAVING MODE FOR R 502 - R 752

After the food processor is plugged in, it needs to be switched on by pressing the "on" button I.

If the processor is not used for 5 minutes, it will go into energy saving mode.

The "on" button needs to be pressed again to switch on the power supply.

### • CONTROL PANEL

Red switch        =    Off switch  
Green switch I   =    Start speed 1  
Black switch     =    Pulse control

### R 502 • R 752:

Green switch II =    Start speed 2

**R 502 V.V. • R 752 V.V.:** Speed variation for **cutter bowl** from 300 to 3,500 rpm. **For vegetable preparation** from 300 to 1,000 rpm.

## • TIMER

### How the timer works

The timer has three 7-segment LED displays, two timer adjustment buttons and a buzzer.

#### a) Countdown

When the food processor is switched on, the timer usually displays **0.00** and can be set directly. This is called Countdown Mode. The timer increments one second at a time when the motor is operating. Incrementation stops if the motor stops then resumes when the motor starts again. In the case of models R 502 V.V. and R 752 V.V., the food processor automatically stops after 9 minutes and the timer stops. In the case of models R 502 and R 752, the food processor automatically stops after 5 minutes and the timer stops.

#### b) Timer

Before starting, the user can adjust the processing time to anywhere between **0.05** (5 seconds) and **9.00** (9 minutes) by pressing the + and – buttons. When the motor starts, the timer increments one second at a time. This is called Timer Mode. Countdown stops if the motor stops and resumes when the motor starts again. When the countdown gets to **0.00**, the processor stops and a buzzer sounds. The time initially set is then displayed again.

#### c) Starting the processor with the Pulse button:

If the food processor is started using the Pulse button, the timer goes into Countdown Mode when the Pulse button is held down and returns to the previous timer display when the Pulse button is released.

#### d) Vegetable preparation function:

The timer displays 3 horizontal dashes but is not working

#### e) Reset

If the timer displays anything other than **0.00** when the motor is not operating, the user can reset the

display to zero by pressing the + and – buttons at the same time or by pressing the “off” button on the food processor for 2 seconds.

#### f) Standby Mode

If the food processor is not used for more than 10 minutes (motor not operating), the timer goes into Standby Mode. Standby Mode can be cancelled by pressing any button or the “on” button.

#### g) Turning off the timer:

If you do not want to use the timer, you can deactivate it by pressing the “on” and “off” buttons at the same time for several seconds.

Repeat the operation to reactivate the timer function.



2) Engage the blade on the motor shaft and lower it right to the bottom of the bowl.

Make sure that it is correctly positioned, by rotating it in the bowl.



## ASSEMBLY

1) With the motor base facing you, position the cutter bowl on the motor base.

Turn the bowl to the right until it locks.



3) Place the lid equipped with the scraper arm on the bowl (see page 11) and turn to the right until locked in place.

The device is now ready for use.

**For models R 502 and R 752**, speed 2 (1,500 rpm) is reserved for the cutter version. If speed 2 is pressed when using the vegetable preparation version, the food processor will start working on speed 1 at 750 rpm.

**For models R 502 V.V. and R 752 V.V.**, the electronic speed variation automatically selects the permitted speed range, which varies between 300 to 3,500 rpm.

## • VEGETABLE PREPARATION ATTACHMENT

The vegetable slicer attachment comprises of two removable parts: the vegetable cutter bowl and lid.

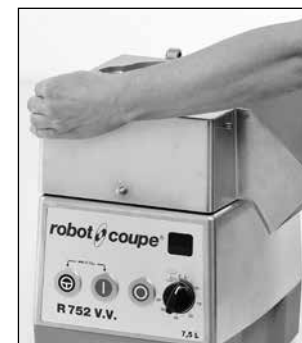

1) With the motor base unit facing your, fit the vegetable cutter bowl onto the motor base unit so that the bowl juts out slightly on the left, with the injection cut on your right. Turn the bowl to the right, until it locks.

(In order to dismount this vegetable preparation bowl, we only need to push on the stainless steel button).

2) Fit the white plastic sling plate onto the motor shaft and check that it is correctly positioned at the bottom of the bowl.

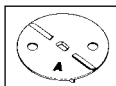

**SIDE A** facing upwards (low ejection rib) for any vegetables or citrus fruit which require careful handling (tomatoes, mushrooms...).

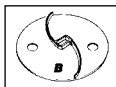

**SIDE B** facing upwards (high ejection rib) for all other types of fruit or vegetables.

3) Position your chosen disc:



**a) If you have opted for a slicing, grating or julienne disc:** position the disc on the motor shaft. To ensure that it is correctly positioned, turn it in a clockwise direction.

**b) You have chosen a dicing unit:** i.e. a grid and a special slicing disc for diced vegetables.

Slicing discs and dicing grids can be mounted in the following combinations:

SLICER	DICING GRID							
	5x5 mm	8x8 mm	10x10 mm	12x12 mm	14x14 mm	20x20 mm	25x25 mm	
5 mm	•							
8 mm		•						
10 mm			•					
12 mm				•				
14 mm					•			
20 mm						•		
25 mm							•	

The combinations in the shaded areas can be supplied on request.

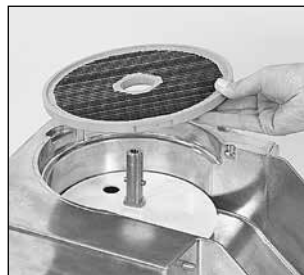

Place the dicing grid in the bowl of the vegetable processor.

Make sure that the spur on the grid is fully engaged in the locking slot of the motor base.

Next, fit the corresponding slicing disc (straight-edged blade) and rotate in a clockwise direction to ensure that it is correctly positioned.



**c) If you want to use the French fries potatoes cutting equipment:**

**This equipment comprises a French fries grid and a special French fries slicing disc.**

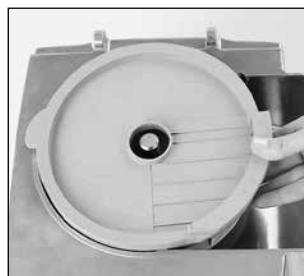

Position the French fries grid in the vegetable preparation bowl.

Check that it is correctly positioned with the French fries plate positioned at the outlet.

Next fit the appropriate slicing disc and rotate in a clockwise direction to check that it is correctly positioned.



4) Position the head of the vegetable preparation machine on the motor shaft. The fastening hook should now be facing you, on your right.



5) Slip the hinge pin into the locations provided at the back of the motor unit.

Next fit the lid securely onto the motor base using the fastening hook. The device is now ready to use.

**For models R 502 and R 752** in the vegetable preparation version, only the first speed (750 rpm) is permitted. Speed 2 (1,500 rpm) is reserved for the cutter version. If speed 2 is pressed when using the vegetable preparation version, the food processor will start working on speed 1 at 750 rpm.

**For models R 502 V.V. and R 752 V.V.,** the speed variation selects automatically the permitted speed range, which varies between 300 and 1,000 rpm.

### TO CHANGE THE DISC:



1) With the motor unit facing you, use your right hand to undo the aluminum fastening hook which holds the vegetable preparation head on the motor unit.

Lift the vegetable preparation head, tilting it back to release the bowl.

2) Remove the disc by lifting it from underneath using the hub and if necessary, turn in an anti-clockwise direction to release.

In the case of dicing or French fries cutting equipment, you should pull out the grid and disc assembly in one go. The discharge plate can then be removed by means of the two holes. Then pull out the discharge plate with the aid of the two holes.

3) When fitting dicing equipment, we recommend that you clean the inside of the bowl with a damp cloth or sponge, particularly the part onto which the grid is to be fitted.

Always use a clean grid.

4) Fit the discharge plate, disc or dicing equipment as indicated in "assembly procedures" in points 1) and 2).

5) Close the lid of the vegetable preparation machine and lock onto the motor unit using the fastening hook.

## USE & EXAMPLES

### • BOWL CUTTER ATTACHMENT

The cutter will enable you to perform all your cutting tasks in minimum time; we recommend therefore, that you keep a close eye on the mixture in order to obtain the desired results.

The pulse control allows you to stop and start the machine for high-precision control when working with certain types of ingredients.

USES	R 502 R 502 V.V. Max Processing quantity (kg)	R 752 R 752 V.V. Max Processing quantity (kg)	R 502 V.V. R 652 V.V. suggested speed (Rpm)	Processing time (mn)
<b>CHOP</b>				
<b>• MEAT</b>				
Hamburger / steak tartare	1,7	3,2	1200/1500	3
Sausage/tomatoes	2,2	3,2	1200/1500	3
Terrine / pâté	2,7	3,2	1200/1500	4
<b>• FISH</b>				
Brandade	2,7	3,2	3000	5
Terrine	2,7	3,2	3000	5
<b>• VEGETABLES</b>				
Garlic / parsley / onion / shallots	0,6/1,1	0,6/1,7	1500/2000	3
Soup / purées	2,2	3,2	2500/3000	4
<b>• FRUITS</b>				
Compotes / purées	2,2	3,2	2500/3000	4
<b>EMULSIFY</b>				
Mayonnaise / aïoli / rémoulade	3,2	3,8	600/1500	3
Hollandaise / béarnaise	2,2	3,2	600/1500	5
Snail or salmon butter	2,2	2,7	600/1500	4
<b>KNEAD</b>				
Shortcrust pastry / Shortbread	2,2	3,2	900/1500	4
Flaky pastry	2,2	3,2	900/1500	4
Pizza dough	2,2	3,2	900/1500	4
<b>GRIND</b>				
Dried fruit	1,1	1,7	900/1500	4
Ice	1,1	1,7	900/1500	4
Breadcrumbs	1,1	1,7	900/1500	4
<b>MIX</b>				
			300/600	

The cutter version has numerous other applications. The above quantities and times are approximate and may vary according to the quality of the ingredients and recipes.

### • VEGETABLE PREPARATION ATTACHMENT

The vegetable preparation attachment consists of two hoppers:

- **one large hopper** for cutting vegetables such as cabbage, celeriac, etc.
- **a cylindrical hopper** for long vegetables and high-precision cutting.

For optimum cutting, use this section as a guide.





#### HOW TO USE THE LARGE HOPPER

- Raise the lever and release the hopper opening.
- Fill hopper with vegetables.
- Replace the lever at the base of the hopper.
- Start to press the lever, switch on machine and maintain pressure until there are no vegetables left in the hopper.

#### HOW TO USE THE CYLINDRICAL HOPPER

- Fill hopper with vegetables.
- Start to press the button and switch on machine.
- maintain pressure until all the vegetables have been processed.

SLICERS	
S 0,6	amands
S 0,8	cabbage
S 1	carrot / cabbage / cucumber / onion / potato / leek
S 2 / S 3	lemon / carrot / mushroom / cabbage / potato / cucumber / courgette / onion / leek / bell pepper
S 4 / S 5	courgette / beetroot / carrot / mushroom / cucumber / bell pepper / radish / lettuce / potato / leek / tomato
S 8 / S 10	courgette / potato / courgette / carrot
S 14	potato / courgette / carrot
S 4 mm	cooked potatoes
S 6 mm	cooked potatoes

RIPPLE CUT SUZER			
R 2	beetroot / potato / carrot / courgette		
R 3	beetroot / potato / carrot / courgette		
R 5	beetroot / potato / carrot / courgette		
GRATER			
G 1,5	celeriac / cheese	G 7	cabbage / cheese
G 2	carrot / celeriac / cheese	G 9	cabbage / cheese
G 3	carrot	Parmesan /chocolate	
G 5	cabbage / cheese	Radish	
JULIENNE			
J 1x8	carrot / celeriac / potato / courgette		
J 1x26	onion / courgette		
J 2x2	carrot / celeriac / potato		
J 2x4	carrot / beetroot / courgette / potato		
J 2x6	carrot / beetroot / courgette / potato		
J 2x10	carrot / beetroot / courgette / potato / celeriac		
J 4x4	eggplant / beetroot / courgette / potato		
J 6x6	eggplant / beetroot / celeriac / courgette / potato		
J 8x8	céleriac / patate		
DICE			
D 5x5	carrot / courgette / cucumber / celeriac		
D 8x8	potato / carrot / courgette / beetroot		
D 10x10	potato / carrot / courgette / beetroot /turnip / onion / apple		
D 14x14	potato / carrot / courgette / turnip / celeriac		
FRENCH FRIES			
F 8x8	potato		
F 10x10	potato		
F 10x16	potato		

## OPTIONS



For the R 502 and R 502 V.V. models, serrated and fine-serrated blades are available as optional extras.

For the R 752 and R 752 V.V. models, serrated and fine-serrated blades are available as optional extras.

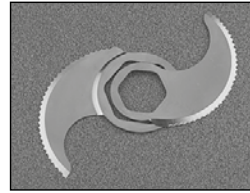

The serrated blades are recommended for grinding and kneading tasks.

The **fine-serrated blades** are used for chopping herbs and spices.

## CLEANING



### WARNING

As a precaution, always unplug your appliance before cleaning it (hazard of electrocution) and handle the blades with care (hazard of injury).

#### • MOTOR BASE

Never immerse the motor base in water. Clean using a damp cloth or sponge.

#### • BOWL CUTTER ATTACHMENT

After removing the lid, remove the bowl from the motor base by pushing the trigger fitted in the handle. Pull up to disengage, leaving the blade in the bowl in order to prevent any spillage when working with liquids.

If the food has a solid consistency, remove the blade and empty the bowl.

Replace the bowl, place the blade back on the shaft and switch on the machine in order to remove any mixture which may have stuck to the blade.

If you wish, you can rinse the bowl by filling it with hot water and switching on for a few minutes.

#### • SCRAPER ARM

To clean the scraper arm, dismantle it as follows: Hold the scraper arm in one hand and the hub in the other hand (drawing 1).

Press the two pieces one on the other, and turn the handle of 45° anticlockwise (drawing 2).

Then it is possible to pull out the two pieces (the scraper arm and the handle) from the lid and clean them (drawing 3).

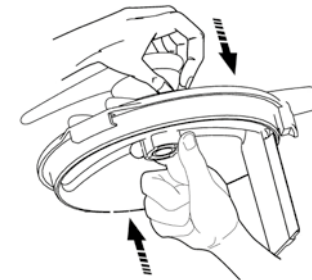

Drawing 1

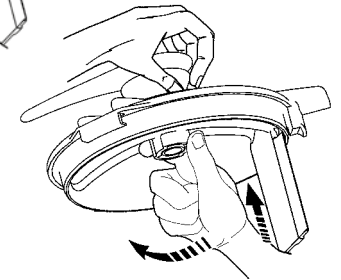

Drawing 2

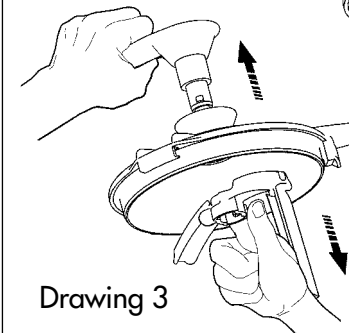

Drawing 3

#### • BLADE

The stainless steel blade of R 752 - R 752 V.V. is easy to dismantle and to clean.

After cleaning the blade, always dry the blades well to prevent rusting.

The blade must always be removed for cleaning

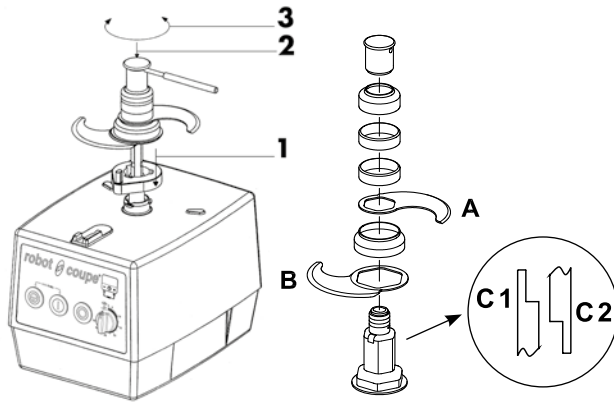

Ensure power supply to machine is disconnected.

- 1 - Place blade dismantling tool over shaft onto motor base.
- 2 - Place blade on shaft.
- 3 - Place dismantling tool in hole over blade nut and turn anti-clockwise to unscrew. To remount, carry out operation in reverse. In both cases, blade is supported by small knob on blade dismantling tool.

When re-assembling do not over tighten.

**A** - Upper blade.

**B** - Lower blade.

**C** - Depending on space required between blades during reassembly, assemble spacers **C** as follows:

**C1** if spacer is placed above blade

**C2** if spacer is placed below blade.

## • VEGETABLE PREPARATION ATTACHMENT

Remove each of the parts, i.e.: the lid, disc, sling plate and bowl by pushing the stainless steel button and clean.

Diswashers are best avoided especially for the lid. Instead we recommend that you clean the machine by hand, using washing-up liquid.

If you do use a dishwasher, we suggest that you use a detergent designed specially for aluminum.



## IMPORTANT

**Check that your detergent is suitable for cleaning plastic parts. Some washing agents are too alkaline (e.g. high levels of caustic soda or ammonia) and totally incompatible with certain types of plastic, causing them to deteriorate rapidly.**

## MAINTENANCE

### • BLADE

Only the smooth blades can be sharpened.

It is strongly recommended, after each use, to give the blades a quick sharpen with a sharpening steel, especially after cutting parsley.

They should then be sharpened properly once a month with the very fine whetstone that comes with the processor.

The quality of the cut depends mainly on the sharpness of your blades and the degree of wear.

The blades are actually wearing parts, which should be replaced occasionally to ensure consistent quality in the final product.

### • SCRAPER ARM

The scraper arm is equipped with rubber pieces which are wearing parts. They should be replaced occasionally to always ensure an optimum efficiency of the scraper arm. The rubber pieces are very easy to remove and remount.

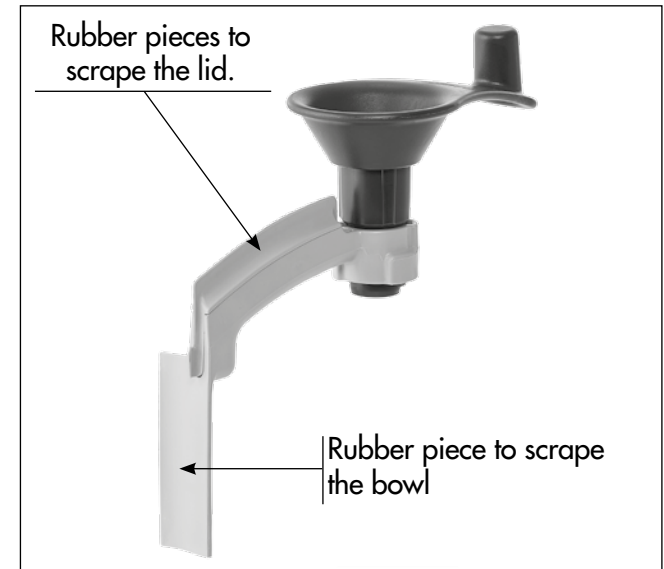

### • MOTOR SEAL

In order to keep the motor completely watertight, it is advisable to check the motor seal regularly for wear and tear and replace if necessary.

The seal must be replaced once a year and once every 6 months in the case of intensive use.

The motor seal can be easily replaced without having to remove the motor, so we strongly advise you to ensure that it is in good condition.

### • BLADES, COMBS AND GRATERS

That blades on the slicing discs, the combs on the julienne discs and the graters are all wearing parts, which have to be changed every so often to ensure high quality cutting.

## TECHNICAL SPECIFICATIONS

### • WEIGHT

	Net	Gross
R 502 G (without disc)	29.4 kg	33.4 kg
R 502 V.V. G (without disc)	29.8 kg	33.8 kg
R 752 (without disc)	33.0 kg	37.0 kg
R 752 V.V. (without disc)	33.5 kg	37.5 kg

### • DIMENSIONS (in mm)

	A	B	C	D	E	F
R 502 G / R 502 V.V. G	540	365	278	270	402	378
R 752 / R 652 V.V.	570	365	278	270	443	378

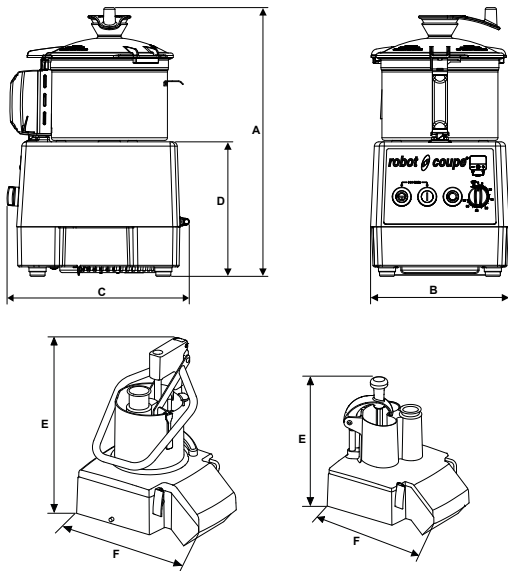

### • WORKING HEIGHT

We recommend that you position the food processor on a stable worktop so that the upper edge of the large feed hopper is at a height of between 1.20 m and 1.30 m.

### • NOISE LEVEL

The equivalent continuous sound level when the food processor is operating on no-load is less than 70 db (A).

### • ELECTRICAL DATA

R 502 V.V. G single-phase machine

Motor	Veg prep speed (rpm)	Cutter speed (rpm)	Intensity (Amp.)
230 V/50-60 Hz	300 to 1,000	300 to 3,500	5.8

R 502 G three-phase machines

Motor	Veg prep speed (rpm)	Cutter speed (rpm)	Intensity (Amp.)
230-400 V/50 Hz	750	1,500	230V=3.9 400V=2.3
400 V/50 Hz	750	1,500	2.2 2.1
220 V/60 Hz	900	1,800	3.8 3.6
380 V/60 Hz	900	1,800	2.2 2.1

R 752 V.V. single-phase machine

Moteur	Vitesse coupe-légumes (tr/mn)	Vitesse cutter (tr/mn)	Intensité (Amp.)
230 V/50-60 Hz	300 à 1000	300 à 3500	5,8

R 752 three-phase machines

Motor	Veg prep speed (rpm)	Cutter speed (rpm)	Intensity (Amp.)
230-400 V/50 Hz	750	1,500	230V=3.1 400V=1.8 230V=3.6 400V=2.1
400 V/50 Hz	750	1,500	3.25 4.6
220 V/60 Hz	900	1,800	6.5 8.5
380 V/60 Hz	900	1,800	2.1 2.2

- Power shown on data plate.

## SAFETY

**These models are fitted with a magnetic safety device and motor braking system.**

As soon as you open the lid of the cutter bowl or the vegetable attachment, the motor stops.

To restart the machine, simply close the lid and press the green switch.

In order to avoid splashing when processing liquid preparation, we recommend you stop the machine before opening the lid.

All the models are fitted with a **thermal cut-out** which automatically stops the motor if the machine is left on for too long or overloaded.

If this happens, allow the machine to cool completely before restarting.



## WARNING

**The blades and discs are extremely sharp.  
Handle with care.**



## REMEMBER

**Never try to override the locking and safety systems.**

**Never insert an object into the container where the food is being processed.**

**Never push the ingredients down with your hand.**

**Do not overload the appliance.**

**Never switch the appliance on when it is empty.**

## STANDARDS

Consult the declaration of compliance on page \$.

SCHEMA ELECTRIQUE

ELECTRIC DIAGRAM

ELEKTRISCHES SCHALTBILD



Important  
Précautions  
Wichtiger Hinweis

Vérifier que le fil d'adaptation à la tension de votre réseau est correctement positionné (voir tableau ci-contre).  
Check that the wire which allows the adaptation to the supply voltage is on the right terminal (table in the margin).  
Unbedingt prüfen, ob der Draht zur Anpassung an die Spannung Ihres Stromnetzes Korrekt positioniert ist (Tafel Gegenüber).

	Français	English	Deutsch
BPA	Bouton poussoir ARRET	OFF switch	Stopschalter
BPV1	Bouton poussoir MARCHE Vitesse 1	Low speed switch	Kleine geschwindigkeitshalter
BPV2	Bouton poussoir MARCHE Vitesse 2	Hight switch	Grosse geschwindigkeitshalter
BPP	Bouton poussoir PULSE	PULSE switch	Impulsschalter
ISCL R502	Interrupteur de Sécurité Poussoir, uniquement présent dans R502	Pusher safety switch, only present in R502	Sicherheitsschalter Stössel, nur in R502
ISCL R752	Interrupteur de Sécurité Poussoir, uniquement présent dans R752	Pusher safety switch, only present in R752	Sicherheitsschalter Stössel, nur in R702
ISCO	Interrupteur de Sécurité Couvercle uniquement présent dans R502 et R752	Feed lead safety switch only present in R502 and R752	Sicherheitsschalter Deckel nur in R502 und R752
ISCU	Interrupteur de Sécurité Cutter	Cutter lid safety switch	Sicherheitsschalter Messerdeckel
MI	Minuterie	Timer	Timer
MO	Moteur	Motor	Motor
P	Platine électronique réf 114600	Electronic Board réf 114600	Elektronische Platine 114600
PTO	Protecteur thermique intégré au moteur	Thermal protector integrated in the motor	Thermoschutz im Motor integriert

**A partir de / From / Von**  
 Blixer 5 G ..... : M82001111XX  
 Blixer 7 ..... : M82601111XX  
 R 5 G ..... : M81701111XX  
 R 7 ..... : M82401111XX  
 R502 G ..... : M81401111XX  
 R752 ..... : M82201111XX

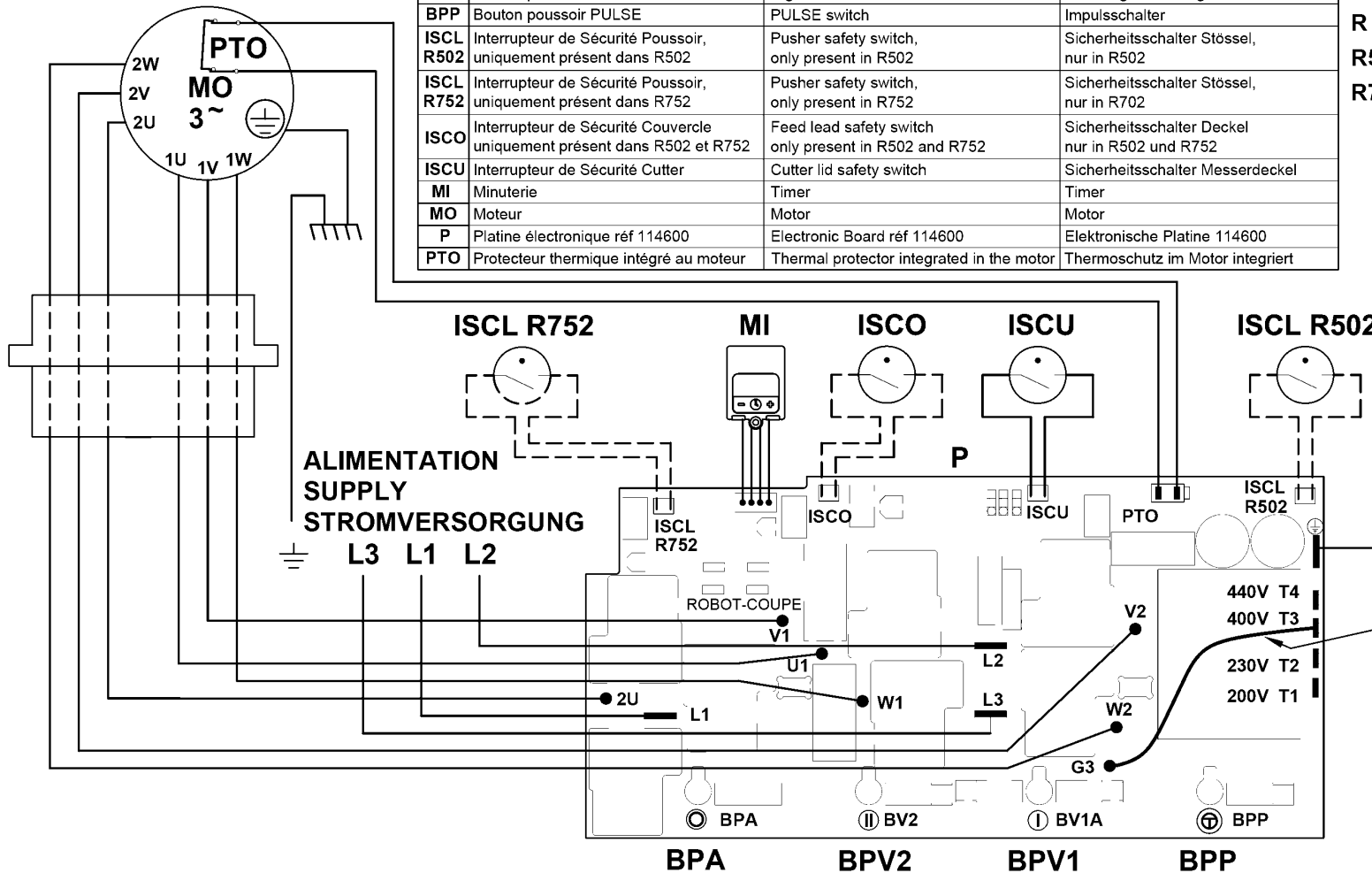

Tension d'alimentation Supply voltage Stromspannung	Connexion Terminal Anschluss
200 V	200 (T1)
220 -> 240 V	230 (T2)
380 -> 415 V	400 (T3)
440 V	440 (T4)

**R5 V.V.G - R7 V.V. - Blixer® 5 V.V.G - Blixer® 7 V.V. - R502 V.V.G - R752 V.V.**  
**SCHEMA ELECTRIQUE** **ELECTRIC DIAGRAM**

200-240V/50-60Hz 1~  
**ELEKTRISCHES SCHALTBILD**

	Français	English	Deutsch
<b>BPA</b>	Bouton poussoir ARRET	OFF switch	Stopschalter
<b>BPM</b>	Bouton poussoir MARCHE	ON switch	Betriebsschalter
<b>BPP</b>	Bouton poussoir PULSE	PULSE switch	Impulsschalter
<b>CB</b>	Carte boutons Réf. 113602	Switches card # 113602	Schalteren Karte. Numer 113602
<b>CC</b>	Carte capteur vitesse Réf. 102920	Speed sensor circuit # 102920	Kaptor Karte. Numer 102920
<b>ISCL R502</b>	Interrupteur de Sécurité Poussoir, uniquement présent dans R502	Pusher safety switch, only present in R502	Sicherheitsschalter Stössel, nur in R502
<b>ISCL R752</b>	Interrupteur de Sécurité Poussoir, uniquement présent dans R752	Pusher safety switch, only present in R752	Sicherheitsschalter Stössel, nur in R752
<b>ISCO</b>	Interrupteur de Sécurité Couvercle uniquement présent dans R502 et R752	Feed lead safety switch only present in R502 and R752	Sicherheitsschalter Deckel nur in R502 und R752
<b>ISCU</b>	Interrupteur de Sécurité Cutter	Cutter lid safety switch	Sicherheitsschalter Messerdeckel
<b>MI</b>	Minuterie	Timer	Timer
<b>MO</b>	Moteur	Motor	Motor
<b>V</b>	Variateur Réf. 112381	Variator # 112381	Variator Numer 112381
<b>PTO</b>	Protecteur thermique intégré au moteur	Thermal protector integrated in the motor	Thermoschutz im Motor integriert

**A partir de / From / Von**  
**R5 V.V. G.....: M8180111101**  
**R7 V.V.....: M8250111101**  
**Blixer 5 V.V.G...: M8210111101**  
**Blixer 7 V.V.....: M8270111101**  
**R502 V.V.G.....: M8150111101**  
**R752 V.V.....: M8230111101**

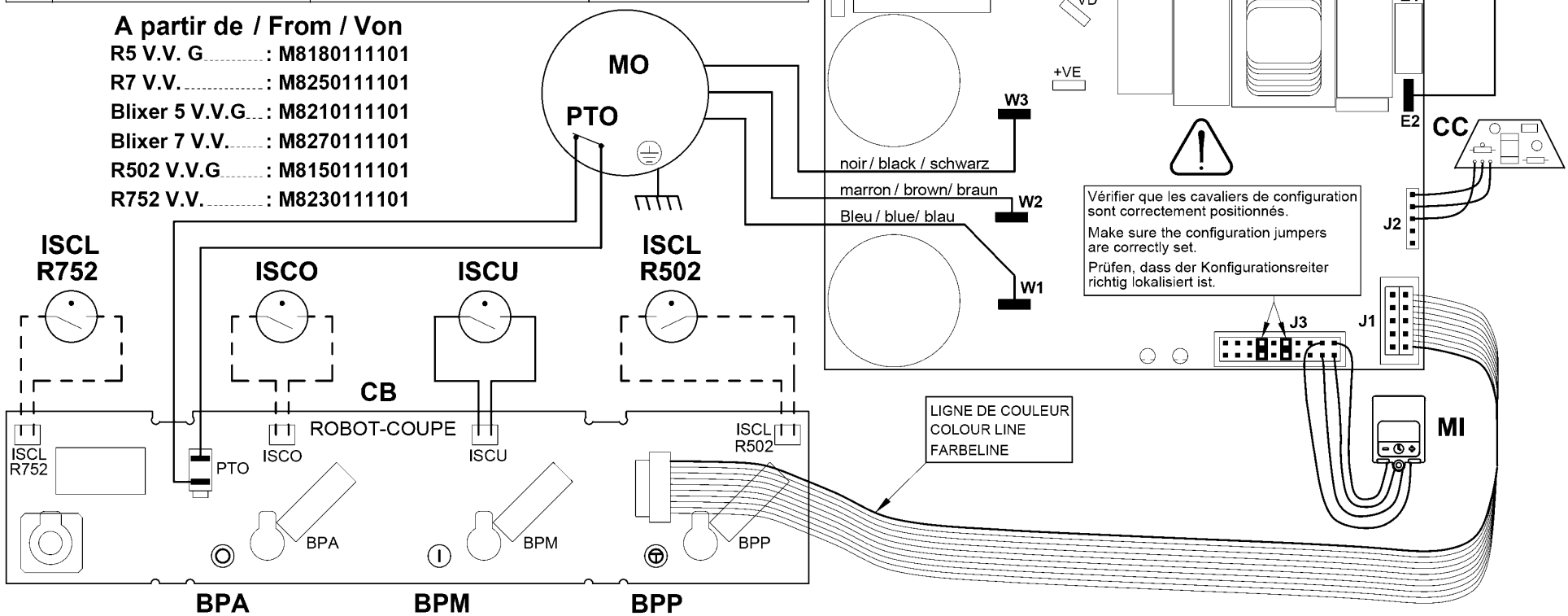



**robot coupe®**

**Head Office, French,  
Export and Marketing Department:**  
48, rue des Vignerons  
94305 Vincennes Cedex- France  
Tel.: 01 43 98 88 15  
Email: international@robot-coupe.com

**Robot Coupe  
Australia Pty Ltd:**  
Unit 3/43 Herbert St  
Artarmon NSW 2064 Australia  
Tel.: (02) 9478 0300  
Email: orders@robotcoupe.com.au

**Robot-Coupe  
U.K. LTD:**  
Fleming Way, Isleworth,  
Middlesex TW7 6EU  
Tel.: 020 8232 1800  
Email: sales@robotcoupe.co.uk



37002314451656

Ref. : 451 656 - 04/09/2020