

robot *coupe*®



New
Register
your product
on line

- **CL 60 E**
- **CL 60 E V.V.**

www.robot-coupe.com

@ Register your product on line

The screenshot displays the Robot-Coupe website's support section. At the top, the navigation bar includes the company logo, links for 'The company', 'Contact us', 'Restricted Area', and 'Select your country...'. Below this, a menu contains 'CATALOGUE', 'SELECTION GUIDE', 'LEAFLETS', 'VIDEOS', 'OUR SUPPORT', and a search bar. The main heading is 'SUPPORT'. The page is divided into two columns. The left column, titled 'Register your product online', provides instructions and a list of required information: 'Product serial number' and 'Purchase date'. A button labeled 'Register my product now' is at the bottom of this column. The right column, titled 'Access the Robot-Coupe after-sales service', features an 'Authentication' form with fields for 'Identifiant', 'Mot de passe', and 'Email', along with a 'Mot de passe perdu' link. A button labeled 'Access the Robot-Coupe after-sales service' is at the bottom of this column.

robot coupe®

DECLARATION OF CONFORMITY

Declares that the machines identified by their type above, comply with:

- The essential requirements of the following European directives and with the corresponding national regulations:
 - Directive «Machinery» 2006/42/EC,
 - Directive «Low voltage» 2014/35/EU,
 - Directive « Electromagnetic compatibility » 2014/30/EU,
 - Regulation (EC) n°1935/2004 « Materials and articles intended to come into contact with food »,
 - Regulation (EU) n°10/2011 « Plastic materials and articles intended to come into contact with food »,
 - Directive «Reduction of Hazardous Substances (RoHS) 2002/95/EC,
 - Directive «WEEE» 2012/19/EU,
- The requirements of the European harmonized standards and with the standards specifying the hygiene and safety requirements:
 - EN ISO 12100: 2010: Safety of machinery – General principles for design,
 - EN 60204-1 -2006: Safety of machinery – Electrical equipment of machines,
 - EN 12852: Food Processors and Blenders,
 - EN 1678-1998: Vegetable Cutting Machines,
 - EN 454 + A1 2010-02: Blender-Mixers,
 - EN 12853: Hand-held Blenders and Whisks (stick blenders),
 - EN 14655: Bread Slicers,
 - EN 13208: Vegetable Preparation Machines,
 - EN 13621: Salad Spinners,
 - EN 60529-2000: Degrees of protection,
 - IP 55 for the electrical controls,
 - IP 34 for the machines.

Montceau en Bourgogne on 4 March 2016

Alain NODET
Industrial Director



SUMMARY

- **WARRANTY**
- **IMPORTANT WARNING**
- **INTRODUCTION TO YOUR NEW VEGETABLE PREPARATION MACHINE CL 60 E • CL 60 E V.V.**
- **SWITCHING ON THE MACHINE**
 - Advice on electrical connections
 - Control panel
- **INSTALLING**
- **FUNCTIONS OF HOPPERS AND THEIR TOOLS**
 - Pusher feed-head
 - Hole feed head
 - Automatic feed head
- **INSTALLING THE DISCS AND TOOLS**
- **INSTALLING THE HOPPERS**
 - Pusher feed-head
 - Hole feed head
 - Automatic feed head
- **CHANGING THE DISCS**
- **CHOOSING THE RIGHT DISC**
- **CLEANING**
- **MAINTENANCE**
 - Motor seal
 - Blades and plates
 - Grating discs
- **TECHNICAL SPECIFICATIONS**
 - Weight
 - Dimensions
 - Working height
 - Noise level
 - Electrical data
- **SAFETY**
- **VARIABLE SPEED CL 60 V.V.**
- **STANDARDS**
- **TECHNICAL DATA**
 - Exploded views
 - Electrical and wiring diagrams

ROBOT-COUPE S.N.C., LIMITED WARRANTY

Your new ROBOT-COUPE appliance is warranted to the original buyer for a period of one year from the date of sale if you bought it from ROBOT-COUPE S.N.C. If you bought your ROBOT-COUPE product from a distributor your product is covered by your distributor's warranty (Please check with your distributor terms and conditions of the warranty).

The ROBOT-COUPE S.N.C. limited warranty is against defects in material and/or workmanship.

THE FOLLOWING ARE NOT COVERED BY THE ROBOT-COUPE S.N.C. WARRANTY:

1 - Damage caused by abuse, misuse, dropping, or other similar damage caused by or resulting from failure to follow assembly, operating, cleaning, user maintenance or storage instructions.

2 - Labour to sharpen and/ or replacements for blades which have become blunt, chipped or worn after a normal or excessive period of use.

3 - Materials or labour to replace or repair scratched, stained, chipped, pitted, dented or discoloured surfaces, blades, knives, attachments or accessories.

4 - Any alteration, addition or repair that has not been carried out by the company or an approved service agency.

5 - Transportation of the appliance to or from an approved service agency.

6 - Labour charges to install or test new attachments or accessories (i.e., bowls, discs, blades, attachments) which have been arbitrarily replaced.

7 - The cost of changing direction-of-rotation of three-phase electric motors (installer is responsible).

8 - SHIPPING DAMAGES. Visible and latent defects are the responsibility of the freight carrier. The consignee must inform the carrier and consignor immediately, or upon discovery in the case of latent defects.

KEEP ALL ORIGINAL CONTAINERS AND PACKING MATERIALS FOR CARRIER INSPECTION.

Neither ROBOT-COUPE S.N.C. nor its affiliated companies or any of its distributors, directors, agents, employees, or insurers will be liable for indirect damage, losses, or expenses linked to the appliance or the inability to use it.

The ROBOT-COUPE S.N.C. warranty is given expressly and in lieu of all other warranties, expressed or implied, for merchantability and for fitness toward a particular purpose and constitutes the only warranty made by ROBOT-COUPE S.N.C. France.

IMPORTANT WARNING

WARNING: In order to limit accidents such as electric shocks or personal injury or fire, and in order to limit material damage due to misuse of the appliance, please read these instructions carefully and follow them strictly. Reading the operating instructions will help you get to know your appliance and enable you to use the equipment correctly. Please read these instructions in their entirety and make sure that anyone else who may use the appliance also reads them beforehand.

UNPACKING

- Carefully remove the equipment from the packaging and take out all the boxes or packets containing attachments or specific items.
- **WARNING** - some of the tools are very sharp e.g. blades, discs, etc..

INSTALLATION

- We recommend you install your machine on a perfectly stable solid base.

CONNECTION

- Always check that your mains supply corresponds to that indicated on the identification plate on the motor unit and that it can withstand the amperage.
- The machine must be earthed.
- With the three-phase version, always check that the blade rotates in an anti-clockwise direction.

HANDLING

- Always take care when handling the blades or discs, as they are extremely sharp.

USE

- Never try to override the locking and safety systems.
- Never insert an object into the container where the food is being processed.
- Never push the ingredients down with your hand.
- Do not overload the appliance.
- Never switch the appliance on when it is empty.

CLEANING

- As a precaution, always unplug your appliance before cleaning it.
- Always clean the appliance and its attachments at the end of each cycle.
- Never immerse the motor base in water.
- For parts made from aluminum, use cleaning fluids intended for aluminum.
- For plastic parts, do not use detergents that are too alkaline (i.e. containing too much caustic soda or ammonia).

- Robot-Coupe can in no way be held responsible for the user's failure to follow the basic rules of cleaning and hygiene.

MAINTENANCE

- Before opening the motor housing, it is absolutely vital to unplug the appliance.
- Check the seals and washers regularly and ensure that the safety devices are in good working order.
- It is particularly important to maintain and check the attachments since certain ingredients contain corrosive agents, e.g. citric acid.
- Never operate the appliance if the power cord or plug has been damaged or if the appliance fails to work properly or has been damaged in any way.
- Do not hesitate to contact your local Maintenance Service if something appears to be wrong.

RECOMMENDATIONS CONCERNING THE INSTALLATION OF VARIABLE-SPEED APPLIANCES AND PERSONAL SAFETY

These recommendations apply to machines equipped with an induction motor and a single-phase wobbulator.

NB :

- The electrical circuit and the protective devices must comply with national regulations.
- The machine must be wired in by a qualified electrician

Protecting your appliance

- Like all electronic devices, wobblators include components that are sensitive to electrostatic discharges (ESDs). Before conducting any work on these wobblators, technicians must therefore rid themselves of electrostatic charges.
- The machine must be disconnected from the mains supply before any internal connection operations are carried out.
- Repeatedly switching on the appliance will cause the wobbulator to overload and may result in its destruction. After the machine has been switched off, you must wait for 3 minutes before switching it back on again.

Wiring

- The appliance requires single-phase* current as far as the wobbulator, which turns the latter into variable-speed three-phase current to supply the motor.

- You must connect the machine to a 200-240V/50 or 60 Hz single-phase* alternating current supply with an earthed socket. A higher voltage will destroy the wobbulator.
- The earthed socket ensures operator safety.

Circuit interrupters ensuring user safety

Ground fault circuit interrupters (GFCIs) intended for variable-speed appliances need to be selected with great care in order to ensure operator safety. GFCIs may be sensitive to alternating current (type AC), impulse current (type A) or all currents (type B).

Danger! Wobblators feature a bridge-connected rectifier of the mains supply voltage. For this reason, in the event of an earth contact, a continuous fault current may fail to trip a differential circuit breaker that is only sensitive to alternating current (type AC).

As the appliance has a single-phase* supply, it is therefore advisable to use a GFCI that is sensitive to impulse current (type A), identified by the following symbol: .

Caution: these GFCIs may go under different names, according to the manufacturer.

Appliances with wobblators produce a fault current on the earth wire. This current may be sufficient to trip the differential circuit breaker unnecessarily. This may occur if :

- Several variable-speed appliances are connected to the same GFCI.
- The appliance produces a fault current that is above the GFCI's actual trip threshold.

Caution: As there are manufacturing tolerances, the actual trip threshold of a GFCI will be between 50% and 100% of its theoretical nominal threshold. Should a problem arise, measure the fault current and the GFCI's actual trip threshold.

You can begin by consulting the characteristics of your appliance in the table below :

Appliance	Mains supply	Conductor Cross-section (mm ²)	GFCI (Ph + N or 3 Ph)	
			Gauge (A)	Threshold (mA)
CL 60 V.V.	180 - 260V 50 or 60 Hz Three-phase	2.5	B 20	≥ 30

* Except for specific three-phase 200-240 V models sold in Japan.

INTRODUCTION TO YOUR NEW VEGETABLE PREPARATION MACHINE CL 60 E • CL 60 E V.V.

The CL 60 is perfectly geared to professional needs. It can perform any number of tasks, which you will gradually discover as you use it.

The CL 60 "E" version is built from stainless steel (100% stainless steel motor base and automatic feed head). It has been designed to operate at **two speeds, 375 and 750 rpm**, in order to ally accuracy of cut with rapidity.

It can be fitted with any one of **4 different feed heads**, in order to increase the machine's output, make the user's job easier and offer the most appropriate tool for each type of preparation. **The heads are designed to be tilted in line with the motor base**, in order to reduce space and facilitate use.

The CL 60 is supplied with a wide range of discs and grids to satisfy even the most demanding chefs when it comes to processing fruit and vegetables, as they can be used for slicing, ribbon cutting, grating, shredding, dicing, chipping and ripple-cutting.

Its numerous functions will open the door to a whole new culinary world.

Thanks to its simple design, all components requiring frequent handling for maintenance or cleaning can be fitted and removed in a trice.

To make things easier for you, this manual supplies a breakdown of all the various fitting operations.

These instructions contain important information designed to help the user get the most out of the CL60 vegetable preparation machine.

We therefore recommend that you read them carefully before using your machine.

We have also included a few examples of use to help you get the feel of your new machine and appreciate its many advantages.

SWITCHING ON THE MACHINE

• ADVICE ON ELECTRICAL CONNECTIONS

Before plugging in your appliance, check that your power supply corresponds to that indicated on the machine's identification plate.



CL 60 Three-phase

ROBOT-COUCPE CL 60 models are fitted with various types of motors : 230 / 400 V switchable / 50 Hz / 3
400 V / 50 Hz / 3
220 V / 60 Hz / 3
380 V / 60 Hz / 3

The machine is supplied with a cable to which you simply attach the appropriate electrical plug for your system. The cable has four wires, one earth wire, plus three phase wires.

If you have a 4-pin plug :

- 1) Connect the green and yellow earth wire to the earth pin.
- 2) Connect the three other wires to the remaining pins.

If you have more than 4 pins in the plug please note the ROBOT-COUCPE does not require a **neutral** wire.

Switch on the empty machine, making sure that the blade is rotating properly in an anti-clockwise direction.

On the motor unit, a red arrow marks the blade rotation direction. If the blade turns in a clockwise direction, swap over two wires :

Since GREEN/YELLOW is the earth, DO NOT DISCONNECT.

Swap either : the ❶ and the ❷
the ❶ and the ❸
the ❷ and the ❸

CL 60 V.V. Single phase (variable speed)

This model is fitted with a 180-260V/50-60 Hz three-phase motor.

However, the machine has a single-phased power supply, which a frequency regular converts into three-phase.

The machine is supplied with a power cord to which you simply attach the appropriate electrical plug for your system. The cable has 3 wires: one earth wire, plus a phase conductor and a neutral wire.

The machine must be fitted with a 20-amp plug.

• CONTROL PANEL

 "Off" button

2 green button :

 "On" button for the first speed (375 rpm)

 "On" button for the second speed (750 rpm)

 CL 60 V.V.: Speed Variation from 100 to 1000 rpm.

INSTALLING

• INSTALL YOUR MACHINE

The CL 60 "E" version is equipped with an Adjustable foot, thanks to this the machine remains stable on all floors.



1. Place the machine at the desired location and unscrew the handle. The foot will automatically adjust its height.
2. Then simply screw the handle to fix the foot.

FUNCTIONS OF HOPPERS AND THEIR TOOLS

• PUSHER FEED-HEAD

This hopper allows you to prepare all types of vegetables:

- the large feed hopper is used to prepare bulky vegetables such as cabbage, celery, lettuce, etc.,
- the tube is used to prepare long or fragile fruit or vegetables.



The lever-fitted feed tube can be adjusted to 3 positions depending on the height of the operator. To change the position, loosen the attachment and adjust to the desired position.

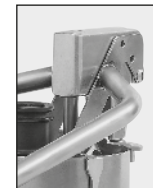

Two types of tool are designed for the lever-type hopper:

1) **The loading cone**, which guides the vegetables (except for cabbage) towards the blades. This tool must be screwed firmly onto the motor shaft.



2) **The hollowing cutter** used only to prepare cabbage.



A special tool for unlocking the cabbage corer.

• HOLE FEED HEADS

4 TUBES FEED-HEAD

This feed-head is equipped with 4 straight holes: 2 straight tubes of 50 mm diameter and 2 straight tubes of 70 mm diameter.

This hopper is designed for the preparation of long vegetables like carrots, cucumbers, leeks, etc., or of fragile fruit and vegetables such as tomatoes, bananas, etc.



STRAIGHT AND SLOPING TUBE HOPPER

This hopper consists of two straight tubes with a diameter of 75 mm diameter, a 50 mm insert and 2 pushers of 50 mm and 70 mm. The insert allows you to modify the diameter of the tubes.



This hopper performs the same functions as the one described above with its straight tube. But it is different in that it is equipped with a sloping tube especially designed for slanted cutting.

No special tool is required to attach these hoppers onto the disc.

• AUTOMATIC FEED-HEAD

This hopper is intended for continuous cutting tasks.

It is ideal for slicing delicate vegetables such as mushrooms and tomatoes, grating carrots, slicing potatoes and cutting french fries, to mention but a few of its uses.



This hopper is not suitable for certain specific tasks, such as :

- slicing long vegetables (use the hole feed-heads).
- preparing bulky vegetables which are too big to be fed into this hopper (use the pusher feed-head).

Make sure that the agitator is in place, in order to avoid blockages and variations in cutting quality. It is vital that this tool be fitted each time the automatic hopper is used.

Two types of tool are designed for the lever-type hopper:

1) **The agitator**, which guides the vegetables (except for cabbage) towards the blades.

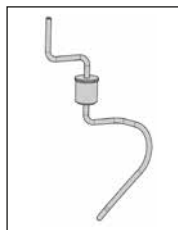

2) Introducing the vegetables too quickly can result in a logjam. If this occurs, clear the blockage using **the crank** supplied for that purpose (all other means are strictly prohibited).

The crank serves to clear the machine if it becomes clogged up with bulky vegetables.

INSTALLING THE DISCS AND TOOLS

Two ejection tools:

The CL 60 is supplied with two ejection tools. The white ejector has been specially designed to cope with cabbage. For all other vegetables, use the black plastic ejector disc.

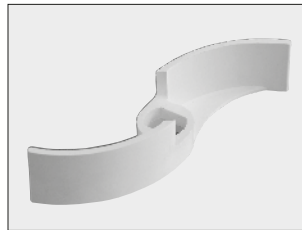

① With the motor unit facing you, slot the black or white ejector tool onto the motor shaft and check that it is properly positioned at the bottom of the bowl.



② Position your chosen disc:



a) **If you have opted for a slicing, grating or julienne disc:**

Position the disc on the motor shaft. To ensure that it is correctly positioned, turn it in a clockwise direction.

b) **You have chosen a dicing unit:**

i.e. a grid and a special slicing disc for diced vegetables.

Slicing discs and dicing grids can be mounted in the following combinations:

Slicer \ Dicing grid	5x5 mm	8x8 mm	10x10 mm	14x14 mm	20x20 mm	25x25 mm
5 mm	•					
8 mm		•				
10 mm			•			
14 mm				•		
20 mm					•	
25 mm						•

You will find all the combinations marked • on our machines and accessories price list.

The dimensions of the dicing grid should always be equal to or greater than those of the slicing disc.

Place the dicing grid in the bowl of the vegetable processor.

Make sure that the spur on the grid is fully engaged in the locking slot of the motor unit.

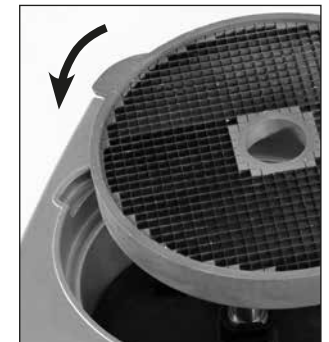

Next, fit the corresponding slicing disc (straight-edged blade) and rotate in a clockwise direction to ensure that it is correctly positioned.

c) If you want to use the French fries potatoes cutting equipment:

This equipment comprises a French fries grid and a special French fries slicing disc.



WARNING PUSHER FEED HEAD



To get the very best results when cutting french fries, remember to insert **the removable divider** in the hopper and load the potatoes into the left-hand compartment (see photo opposite).

Position the French fries grid in the vegetable preparation bowl.

Check that it is correctly positioned with the French fries plate positioned at the outlet.





No tools (loading cone or cabbage corer) are required when using the divider.

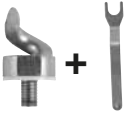

Next fit the appropriate slicing disc and rotate in a clockwise direction to check that it is correctly positioned.

④ The choice of disc-fixing tool will vary according to the hopper and the type of vegetable:

Hopper	Vegetable	Tool	
Pusher	All types except for cabbage and french fries	Loading cone	
Pusher	Cabbage	Cabbage corer + key	
Pusher	French fries	Removable partition	
Automatic	All	Agitator	
4-hole	All	No tool	

Screw the tool (unless you are using the removable partition) firmly onto the motor shaft.

INSTALLING THE HOPPERS

• PUSHER FEED-HEAD

USING THE FEED TUBE

Fill the feeder right up to the top with vegetables. Apply a downwards pressure on the pusher and maintain it until all the vegetables have been processed.

Always press the vegetables down with a pusher to improve cutting efficiency.

HOW TO USE THE CYLINDRICAL HOPPER



WARNING



To get the very best results when cutting french fries, remember to insert **the removable divider** in the hopper and load the potatoes into the left-hand compartment (see photo opposite).

① Position the veg prep hopper on the motor unit. The locking handle should be facing you, on the right.



② Slide the hinge pin into the slots provided at the back of the motor base.

Next, lock the lid onto the motor unit using the locking handle.

- Fill the feeder right up to the top with vegetables.
- Lower the pusher so that it is flush with the top of the feed opening.

- Press the pusher down to guide the food through the machine. The exact amount of pressure required will depend on the nature of the cut, bearing in mind that too much force reduces cutting quality without increasing throughput.
- Cut cabbages in half and remove the core before processing, in order to avoid unnecessary strain and ensure an end-product of a higher quality.
- Lift the pusher and allow access to the feed tube.

• HOLE FEED HEADS

❶ Position the 4-hole hopper, or the straight and inclined hole hopper, on the motor unit. The locking handle should now be facing you, on the right.



❷ Slip the hinge pin into the locations provided at the back of the motor base. The locking handle should now be facing you, on the right.



• AUTOMATIC FEED-HEAD

❶ et ❷ Proceed as specified for the pusher-feed head.

❸ Screw the agitator onto the motor shaft. Screw the agitator onto the motor shaft.



❹ Position the automatic hopper on the motor base. The fastening hook is now facing you on your right.

❺ Slide the hinge pin into the slots provided at the back of the motor base.

Then, lock the lid onto the motor base using the fastening hook.



❻ Insert the crank into the central hub of the head. Turn it until the part is inside the hub.

CHANGING THE DISCS

The machine should be switched off (by pressing the red push-button) before starting to change the disc.

❶ With the motor unit facing you, use your right hand to release the aluminium fastening hook used to lock the hopper onto the motor base.

❷ a) **Feed opening fitted with a lever:**

Lift the pusher and release the bowl by tilting it to the left so that the hopper can be tilted backwards. Then inscrew the loading cone or the hollowing cutter. For the hollowing cutter, use the dismantling tool provided for that purpose.

b) **With hole feed-head:**

First remove the inserts and the pushers and then lift the fastening hood in order to tilt the hopper backwards to release the bowl.

c) **Automatic feeder:**

Lift the fastening hook in order to tilt the hopper backwards to release the bowl.

③ Free the disc by lifting it by its edges.

For dicing equipment, you are advised to pull out the grid and disc assembly together. Then remove the discharge disc using the two holes.

If the disc is stuck, turn it slightly in the anticlockwise direction.

④ When fitting dicing equipment, it is advisable to clean the inside of the bowl thoroughly with a damp cloth or sponge, especially the part onto which the grid is to be fitted.

We recommend that you remove the grid and disc together. To make the job easier, turn the ejector disc.



Always use a properly cleaned grid. Never process soft foodstuffs after hard ones without properly cleaning the grid beforehand.



Use our **D-Clean Kit** (ref. 39881) to clean your 5x5, 8x8 and 10x10 dicing grids quickly and easily.

⑤ Then fit the discharge disc, the slicing, grating or julienne disc, or the dicing equipment as described in steps 1) and 2) in the previous section on the relevant hopper.

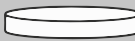
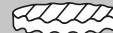
⑥ Close the lid using the fastening hook.

CHOOSING THE RIGHT DISC

SLICERS 			
S 0,6	amands		
S 0,8	cabbage		
S 1	carrot / cabbage / cucumber / onion / potato / leek		
S 2 / S 3	lemon / carrot / mushroom / cabbage / potato / cucumber / courgette / onion / leek / bell pepper		
S 4 / S 6	courgette / beetroot / carrot / mushroom / cucumber / bell pepper / radish / lettuce / potato / leek / tomato		
S 8 / S 10	courgette / potato / courgette / carrot		
S 1 4	potato / courgette / carrot		
RIPPLE CUT SUCER 			
R 2	beetroot / potato / carrot / courgette		
R 3	beetroot / potato / carrot / courgette		
R 5	beetroot / potato / carrot / courgette		
GRATER 			
G 1,5	celeriac / cheese	G 7	cabbage / cheese
G 2	carrot / celeriac / cheese	G 9	cabbage / cheese
G 3	carrot		Parmesan/chocolate
G 5	cabbage / cheese		Radish
JULIENNE 			
J 1x8	carrot / celeriac / potato / courgette		
J 2x2	carrot / celeriac / potato		
J 2,5x2,5	carrot		
J 2x4	carrot / beetroot / courgette / potato		
J 2x6	carrot / beetroot / courgette / potato		
J 2x10	carrot / beetroot / courgette / potato / celeriac		
J 4x4	eggplant / beetroot / courgette / potato		
J 6x6	eggplant / beetroot / celeriac / courgette / potato		
J 8x8	celeriac / potato		

DICE 	
D 5x5	carrot / courgette / cucumber / celeriac
D 8x8	potato / carrot / courgette / beetroot
D 10x10	potato / carrot / courgette / beetroot / turnip / onion / apple (fruit)
D 14x14	potato / carrot / courgette / turnip / celeriac
D 20x20	potato / carrot / courgette / pineapple / turnip
D 25x25	potato / courgette / turnip / apple (fruit) / melon / watermelon
D 50x75	salad
FRENCH FRIES 	
F 8x8	potato
F 10x10	potato
F 10x16	potato

CLEANING

 **WARNING**

As a precaution, always unplug your appliance before cleaning it (risk of electrocution).

After removing the head of the vegetable preparation machine, take off the disc, followed by the grid and discharge plate where necessary.

Dishwashers are best avoided in order to prevent the aluminium from becoming tarnished. Instead we recommend that you clean the machine by hand using washing-up liquid.

If you do put your machine in a dishwasher, we suggest that you use a detergent designed specially for aluminium.

Never immerse the motor base in water. Clean it with a damp cloth or sponge.



IMPORTANT

Check that your detergent is suitable for cleaning plastic parts. Some washing agents are too alkaline (e.g. high levels of caustic soda or ammonia) and totally incompatible with certain types of plastic, causing them to deteriorate rapidly.

MAINTENANCE

• MOTOR SEAL

The motor seal on the shaft should be lubricated regularly using a food safe lubricant.

In order to keep the motor completely watertight, it is advisable to check the motor seal regularly for wear and tear and replace if necessary.

The motor seal can be easily replaced without having to remove the motor, so we strongly advise you to ensure that is in good condition.

• BLADES AND PLATES

The blades on all our discs are wearing parts that need to be replaced from time to time, in order to maintain consistently high cutting quality.

• GRATING DISCS

Grating discs deteriorate over time. We recommend you replace them from time to time, in order to maintain consistently high cutting quality.

TECHNICAL SPECIFICATIONS

• WEIGHT

	Net	Gross
Motor base	43 kg	57 kg
Automatic feed-head	13 kg	16 kg
Pusher feed-head	7 kg	12 kg
Hole feed-heads	8 kg	11 kg
Trolley	8 kg	10 kg
Disc	0,5 kg	0,6 kg

• DIMENSIONS (in mm)

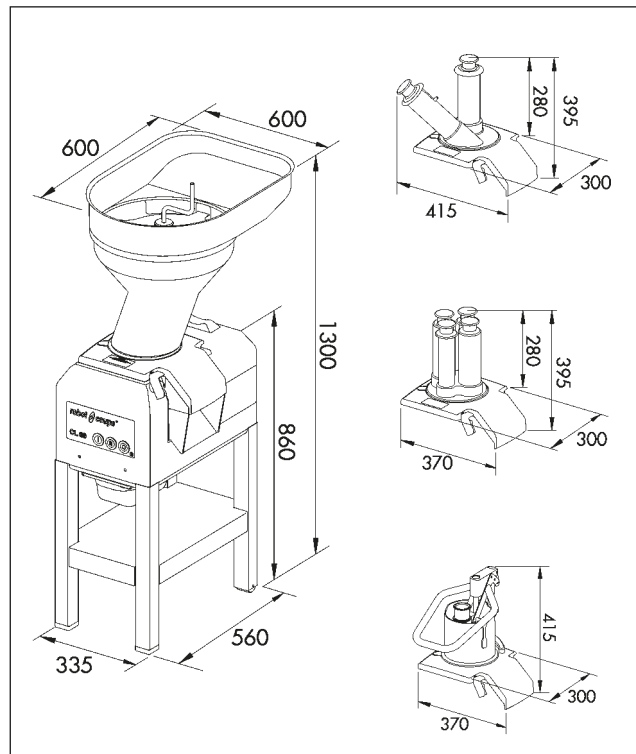

• WORKING HEIGHT

We advise you to place your CL 60 on a stable surface. There is no recommended working height as this is a floor-standing model.

• NOISE LEVEL

The equivalent continuous sound level when the CL 60 is operating on no-load is less than 70 dB (A).

• ELECTRICAL DATA

CL 60 V.V. single-phase supply

Motor	Speed (rpm)	Intensity (amp.)
230 V/50-60 Hz	100 to 1000	5,8

CL 60 three-phase

Motor	Speed (rpm)	Intensity (amp.)
230/400 V/50 Hz switchable	375	230 V=4,5 400 V=2,6
	750	230 V=4,1 400 V=2,3
400 V/50 Hz	375	2,7
	750	3,4
220 V/60 Hz	450	4,7
	900	6,5
380 V/60 Hz	450	2,5
	900	3,5

- Power shown on data plate.

SAFETY



WARNING

**THE DISCS ARE EXTREMELY SHARP.
HANDLE WITH CARE.**

The CL 60 is fitted with magnetic safety system which stops the motor as soon as the large hopper or lid is opened, thus preventing any access to the cutting tool while it is in motion.

As soon as the lid opens, the motor stops.

To restart your machine, simply relock the lid and press the green switch.

When using the hopper equipped with a lever, the motor is stopped as soon as the lever is removed from the bowl. To start the machine again, you should simply position the lever at the aligned with the base of the bowl.

These models are fitted with a **thermal safety device** which automatically stops the motor if the machine is left on for too long or is overloaded.

The hinge pin must be fitted in its position at the back of the motor unit before the machine is switched on.



RE M I N D E R

Never try to override the locking and safety systems.

Never insert an object into the container where the food is being processed.

Never push the ingredients down with your hand.

Do not overload the appliance.

Never switch the appliance on when it is empty.

CL 60 V.V. VARIABLE SPEED

• CHARACTERISTICS

The **CL 60 V.V. variable speed** model allows for an even greater quality of cut thanks to a range of speeds going from 100 to 1000 rpm.

This speed variation allows you to adapt the speed according to the type of cut and texture of the fruit or vegetable being processed. This guarantees optimum accuracy and quality of cut.

The standard CL 60 V.V. variable speed model is fitted with a **stainless steel automatic feed head**. It **can be equipped as an option with a pusher feed head and a hole feed head**.

STANDARDS

Consult the declaration of compliance on page 3.

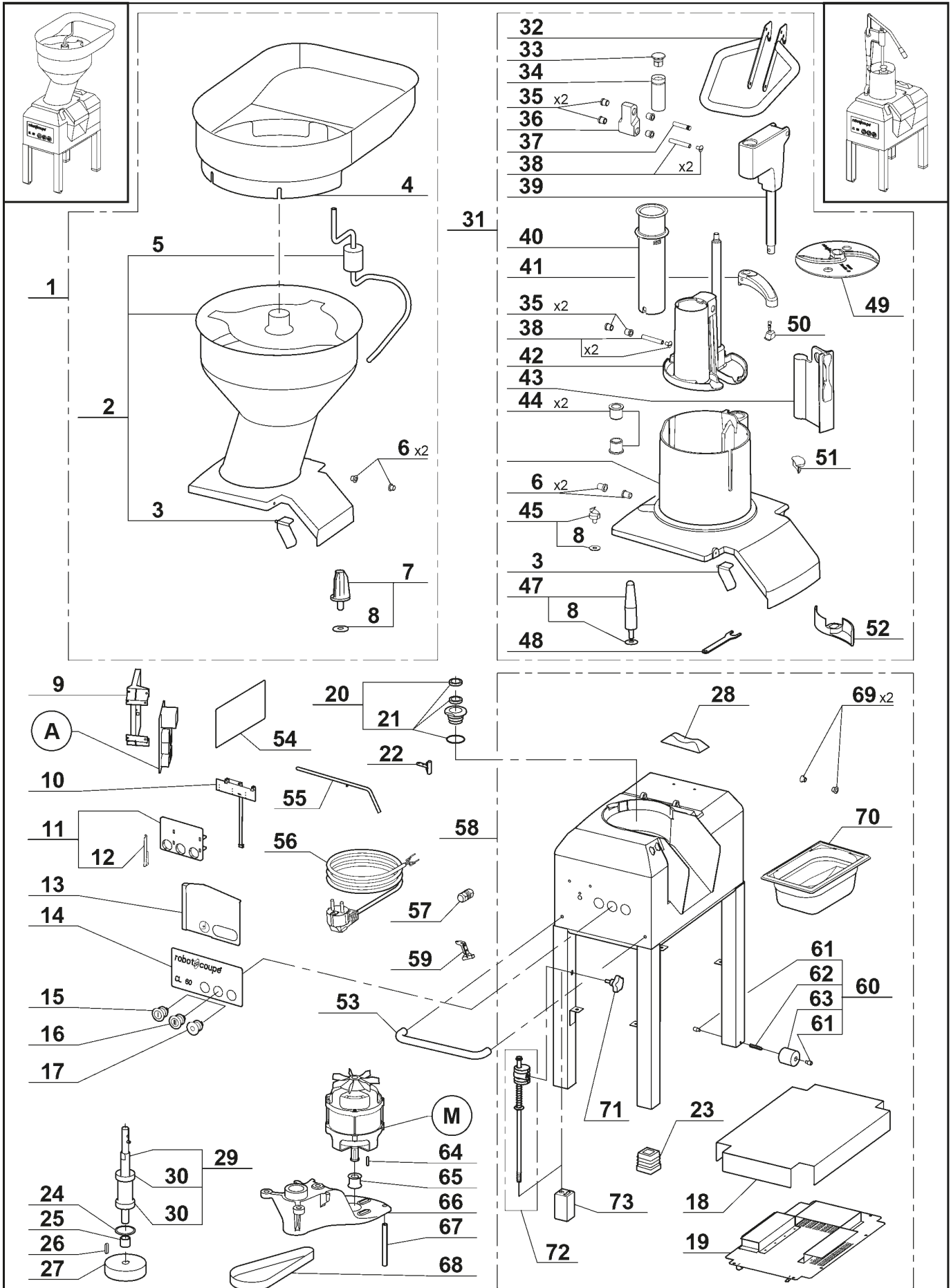

* Voir tarif machines / See export price list

Maj : 03/2016 | REV : c

CL 60 E
N° de série / Serial number
 - 684 - - - - -

Index	Pièce / Part	Désignation	Description
1	39 681	GOULOTTE AUTOMATIQUE INOX	STAINLESS STEEL BULK FEED HEAD
2	29 928	GOULOTTE	FEED HEAD
3	29 925	ENS. TAQUET D'ACCROCHAGE	LID LATCH ASSEMBLY
4	117 774	PLATEAU D'ALIMENTATION	FEEDING TRAY
5	117 775	MANIVELLE	CRANK
6	39 705	ENS BAGUE EPAULEES (Qté=2)	SHOULDERED RING ASSEMBLY
7	117 777	AGITATEUR	AGITATOR
8	117 200	RONDELLE ANTI FRICTION	ANTI-FRICTION WASHER
9	117 809	SUPPORT PLATINE	CIRCUIT BOARD SUPPORT
10	117 813	CARTE BOUTONS	SWITCHES BOARD
11	29 533	ENS. SUPPORT PLATINE	CONTROL BOARD SUPPORT ASSEMBLY
12	117 703	CLAVETTE FIXATION PLASTIQUE	PLASTIC KEY
13	118 586	SUPPORT PLATINE	CONTROL BOARD SUPPORT
14	403 979	PLAQUE FRONTALE	FRONT PLATE
15	502 170	BOUTON VERT VITESSE 1	GREEN KNOB SPEED 1
16	503 268	BOUTON VERT VITESSE 2	GREEN KNOB SPEED 2
17	502 169	BOUTON ROUGE	RED KNOB
18	118 850	PLATEAU DE RENFORT	REINFORCEMENT TRAY
19	118 849	PLAQUE DE FOND	BOTTOM PLATE
20	29 907	ENS. DOUILLE ETANCHEITE	SEALING SOCKET ASSEMBLY
21	29 906	ENS. JOINTS ETANCHEITE	SEALS ASSEMBLY
22	29 451	ENS. ILS COUVERCLE	LID SAFETY SWITCH ASSEMBLY
23	118 527	PIED CAOUTCHOUC (Qté=1)	RUBBER FOOT (Qty=1)
24	200 008	CIRCLIPS Ø 52 INT	BUSHING
25	118 584	ENTRETOISE H 22,5	SPACER H 22,5
26	203 157	CLAVETTE 6x6x30	KEY 6x6x30
27	118 585	POULIE RECEPTRICE	DRIVEN PULLEY
28	39 087	BUTEE COUVERCLE CAOUTCHOUC	RUBBER LID STOP
29	29 915	ENS. AXE	SHAFT ASSEMBLY
30	504 328	ROULEMENT (6304 2RS)	BALL BEARING
31	39 680	COUVERCLE COMPLET	COMPLETE FEED LEAD
32	39 684	POIGNEE CL60E	HANDLE CL60E
33	39 663	BUTEE DE POUSSOIR	PUSHER ABUTMENT
34	39 672	BAGUE DE GLISSEMENT	RING OF SLIDING
35	39 664	BAGUE EPAULEE (Qté=2)	SHOULDERED RINGS (Qty=2)
36	39 665	BIELLETTE ARRIERE	BACK TIEROD
37	39 666	AXE PIVOT 8x40 MOL	AXLE 8x40
38	39 667	AXE PIVOT 8x50	AXLE 8x50
39	39 668	GUIDE POUSSOIR MONTE	PUSHER GUIDE ASSEMBLY
40	39 662	POUSSOIR CAROTTE	CARROTS PUSHER
41	39 671	PORTE AIMANT MONTE	MAGNET HOLDER ASSEMBLY
42	39 669	POUSSOIR LEGUME MONTEE	VEGETABLE PUSHER ASSEMBLY
43	39 660	CLOISON AMOVIBLE	REMOVABLE WALL
44	39 670	PALIER EPAULE 15x25 (Qté=2)	SHOULDERED RINGS 15x25 (Qty=2)
45	29 692	ENSEMBLE EVIDOIR	GOUGE ASSEMBLY
47	29 156	ENS. CONE CHARGEMENT	FEEDING CONE ASSEMBLY
48	118 436	CLEF EVIDOIRE	GOUGE WRENCH
49	102 690	DISQUE EVACUATEUR	DISCHARGE PLATE
50	29 706	ENSEMBLE BUTEE POUSSOIR	PUSHER STOP ASSEMBLY
51	117 321	BUTEE ANTI FRICTION	ANTI-FRICTION STOP
52	118 420	EVACUATEUR CHOUX	CABBAGE DISCHARGE PADDLE
53	39 682	POIGNEE BATI	HANDLE
54	407 295	PLAQUE DISQUES	DISCS PLATE
55	118 582	TIGE DE VERROUILLAGE	LOCKING ROD
56	503 272	CABLE D'ALIMENTATION	POWER CORD
57	39 071	ENSEMBLE ARRET DE CABLE	STRAIN RELIEF ASSEMBLY

CL 60 E
N° de série / Serial number
 - 684 - - - - -

Index	Pièce / Part	Désignation	Description
58	39 683	ENSEMBLE BATI	MOTOR HOUSING FRAME ASSEMBLY
59	29 914	ENS. ILS TAQUET D'ACCROCHAGE	LID LATCH SAFETY SWITCH ASSEMBLY
60	29 908	ENS. ROULETTE	WHEEL ASSEMBLY
61	118 566	AXE ROULETTE (Qté=1)	WHEEL SHAFT (Qty=1)
62	118 567	RESSORT ROULETTE	WHEEL SPRING
63	118 565	ROULETTE	WHEEL
64	203 164	CLAVETTE 6x6x25	KEY 6x6x25
65	100 869	POULIE MOTRICE	DRIVING PULLEY
66	118 529	SUPPORT MECANIQUE	MECHANICAL SUPPORT
67	203 104	VIS D'APPUI	SUPPORTING SCREW
68	500 845	COURROIE 670 5M 25	BELT 670 5M 25
69	29 058	ENS BAGUE EPAULEES (Qté=2)	SHOULDERED RING ASSEMBLY
70	39 318	BAC GASTRONOME 1/4	CONTAINER 1/4
71	49 176	MOLETTE PIED REGLABLE	LOCKING KNOB
72	49 177	MECANISME PIED REGLABLE	ADJUSTABLE FOOT SYSTEME
73	49 178	PIED CAOUTCHOUC REGLABLE	ADJUSTABLE RUBBER FOOT

Index	Désignation	Description
A	PLATINE	CONTROL BOARD
M	MOTEUR	MOTOR

Machine	Voltage	A	M
2310 / 2313 / 2319 / 2325 / 2332	400/50/3	103 700	303 105
2335 / 2314 / 2320 / 2326 / 2338	380/60/3	103 700	303 107
2334 / 2315 / 2321 / 2327 / 2337	220/60/3	103 700	303 106
2336	200/50-60/3	103 700	303 106
2316 / 2322 / 2328	230/400/50/3	113 700	303 108

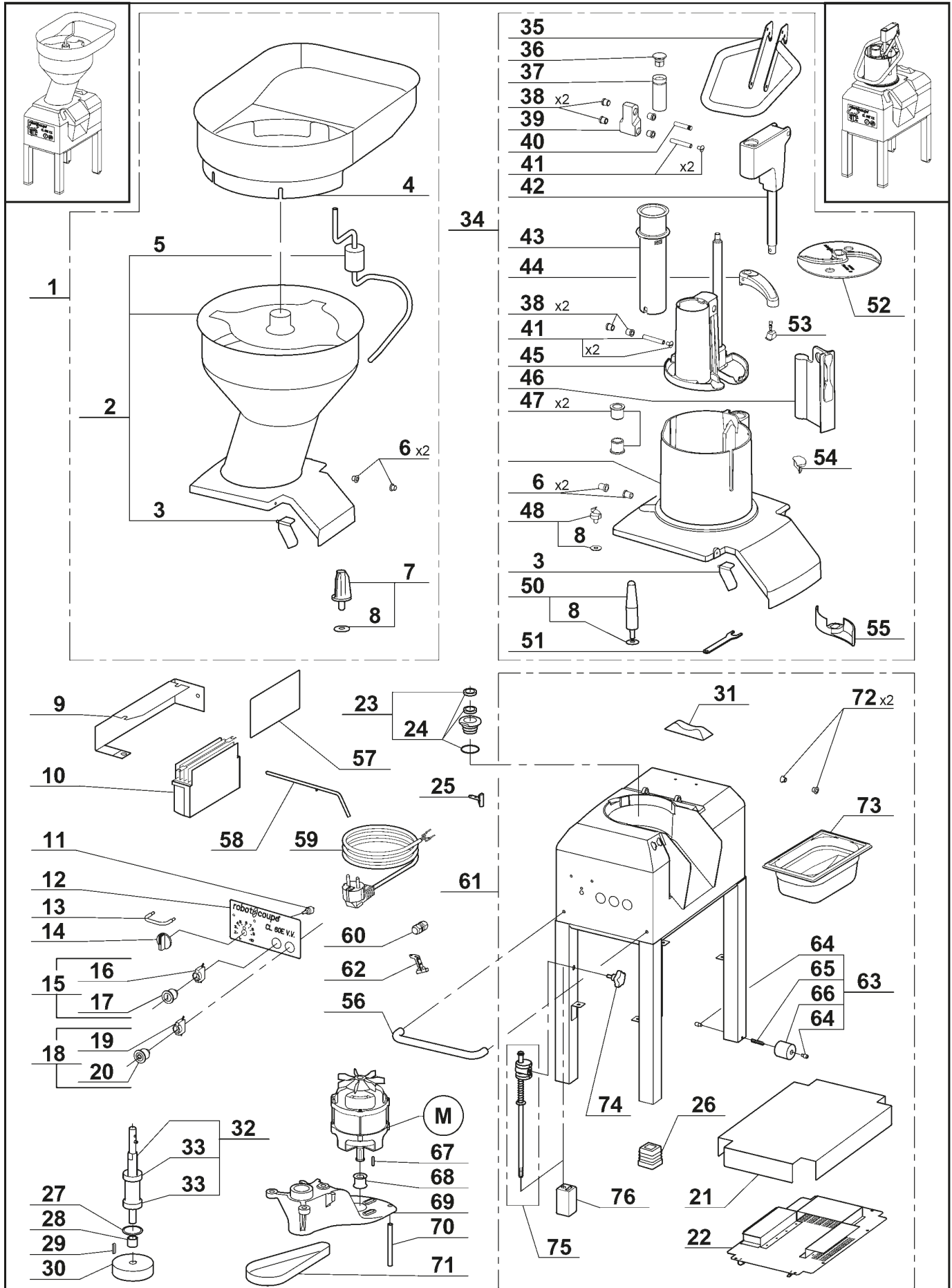

* Voir tarif machines / See export price list

Maj : 03/2016 | REV : c

CL 60 E V.V.
N° de série / Serial number
 - 685 - - - - -

Index	Pièce / Part	Désignation	Description
1	39 681	GOULOTTE AUTOMATIQUE INOX	STAINLESS STEEL BULK FEED HEAD
2	29 928	GOULOTTE	FEED HEAD
3	29 925	ENS. TAQUET D'ACCROCHAGE	LID LATCH ASSEMBLY
4	117 774	PLATEAU D'ALIMENTATION	FEEDING TRAY
5	117 775	MANIVELLE	CRANK
6	39 705	ENS BAGUE EPAULEES (Qté=2)	SHOULDERED RING ASSEMBLY
7	117 777	AGITATEUR	AGITATOR
8	117 200	RONDELLE ANTI FRICTION	ANTI-FRICTION WASHER
9	119 126	SUPPORT VARIATEUR	VARIATOR SUPPORT
10	501 466	VARIATEUR	VARIATOR
11	501 947	POTENTIOMETRE	POTENTIOMETER
12	403 981	PLAQUE FRONTALE	FRONT PLATE
13	29 220	ENS. PROTECTEUR	PROTECTOR ASSEMBLY
14	117 073	POIGNEE POTENTIOMETRE	POTENTIOMETER HANDLE
15	502 174	ENS. BOUTON MARCHE	START KNOB ASSEMBLY
16	500 846	BLOC CONTACT VERT	GREEN SWITCH BLOCK
17	502 170	BOUTON VERT	GREEN KNOB
18	502 173	ENS. BOUTON ARRET	STOP KNOB ASSEMBLY
19	500 847	BLOC CONTACT ROUGE	RED SWITCH BLOCK
20	502 169	BOUTON ROUGE	RED KNOB
21	118 850	PLATEAU DE RENFORT	REINFORCEMENT TRAY
22	118 849	PLAQUE DE FOND	BOTTOM PLATE
23	29 907	ENS. DOUILLE ETANCHEITE	SEALING SOCKET ASSEMBLY
24	29 906	ENS. JOINTS ETANCHEITE	SEALS ASSEMBLY
25	29 451	ENS. ILS COUVERCLE	LID SAFETY SWITCH ASSEMBLY
26	118 527	PIED CAOUTCHOUC (Qté=1)	RUBBER FOOT (Qty=1)
27	200 008	CIRCLIPS Ø 52 INT	BUSHING
28	118 584	ENTRETOISE H 22,5	SPACER H 22,5
29	203 157	CLAVETTE 6x6x30	KEY 6x6x30
30	118 585	POULIE RECEPTRICE	DRIVEN PULLEY
31	39 087	BUTEE COUVERCLE CAOUTCHOUC	RUBBER LID STOP
32	29 915	ENS. AXE	SHAFT ASSEMBLY
33	504 328	ROULEMENT (6304 2RS)	BALL BEARING
34	39 680	COUVERCLE COMPLET	COMPLETE FEED LEAD
35	39 684	POIGNEE CL60E	HANDLE CL60E
36	39 663	BUTEE DE POUSSOIR	PUSHER ABUTMENT
37	39 672	BAGUE DE GLISSEMENT	RING OF SLIDING
38	39 664	BAGUE EPAULEE (Qté=2)	SHOULDERED RINGS (Qty=2)
39	39 665	BIELLETTE ARRIERE	BACK TIEROD
40	39 666	AXE PIVOT 8x40 MOL	AXLE 8x40
41	39 667	AXE PIVOT 8x50	AXLE 8x50
42	39 668	GUIDE POUSSOIR MONTE	PUSHER GUIDE ASSEMBLY
43	39 662	POUSSOIR CAROTTE	CARROTS PUSHER
44	39 671	PORTE AIMANT MONTE	MAGNET HOLDER ASSEMBLY
45	39 669	POUSSOIR LEGUME MONTEE	VEGETABLE PUSHER ASSEMBLY
46	39 660	CLOISON AMOVIBLE	REMOVABLE WALL
47	39 670	PALIER EPAULE 15x25 (Qté=2)	SHOULDERED RINGS 15x25 (Qty=2)
48	29 692	ENSEMBLE EVIDOIR	GOUGE ASSEMBLY
50	29 156	ENS. CONE CHARGEMENT	FEEDING CONE ASSEMBLY
51	118 436	CLEF EVIDOIRE	GOUGE WRENCH
52	102 690	DISQUE EVACUATEUR	DISCHARGE PLATE
53	29 706	ENSEMBLE BUTEE POUSSOIR	PUSHER STOP ASSEMBLY
54	117 321	BUTEE ANTI FRICTION	ANTI-FRICTION STOP
55	118 420	EVACUATEUR CHOUX	CABBAGE DISCHARGE PADDLE
56	39 682	POIGNEE BATI	HANDLE
57	407 295	PLAQUE DISQUES	DISCS PLATE

CL 60 E V.V.
N° de série / Serial number
 - 685 - - - - -

Index	Pièce / Part	Désignation	Description
58	118 582	TIGE DE VERROUILLAGE	LOCKING ROD
59	503 272	CABLE D'ALIMENTATION	POWER CORD
60	39 071	ENSEMBLE ARRET DE CABLE	STRAIN RELIEF ASSEMBLY
61	39 683	ENSEMBLE BATI	MOTOR HOUSING FRAME ASSEMBLY
62	29 914	ENS. ILS TAQUET D'ACCROCHAGE	LID LATCH SAFETY SWITCH ASSEMBLY
63	29 908	ENS. ROULETTE	WHEEL ASSEMBLY
64	118 566	AXE ROULETTE (Qté=1)	WHEEL SHAFT (Qty=1)
65	118 567	RESSORT ROULETTE	WHEEL SPRING
66	118 565	ROULETTE	WHEEL
67	203 164	CLAVETTE 6x6x25	KEY 6x6x25
68	100 869	POULIE MOTRICE	DRIVING PULLEY
69	118 529	SUPPORT MECANIQUE	MECHANICAL SUPPORT
70	203 104	VIS D'APPUI	SUPPORTING SCREW
71	500 845	COURROIE 670 5M 25	BELT 670 5M 25
72	29 058	ENS BAGUE EPAULEES (Qté=2)	SHOULDERED RING ASSEMBLY
73	39 318	BAC GASTRONOME 1/4	CONTAINER 1/4
74	49 176	MOLETTE PIED REGLABLE	LOCKING KNOB
75	49 177	MECANISME PIED REGLABLE	ADJUSTABLE FOOT SYSTEME
76	49 178	PIED CAOUTCHOUC REGLABLE	ADJUSTABLE RUBBER FOOT

Index	Désignation	Description
M	MOTEUR	MOTOR

Machine	Voltage	M
2311 / 2317 / 2323 / 2329 / 2333	230/50/1	303 112

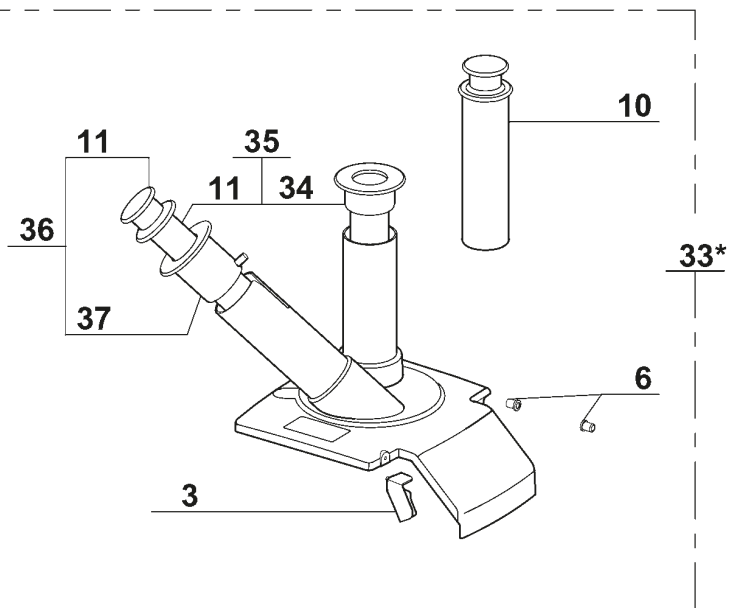
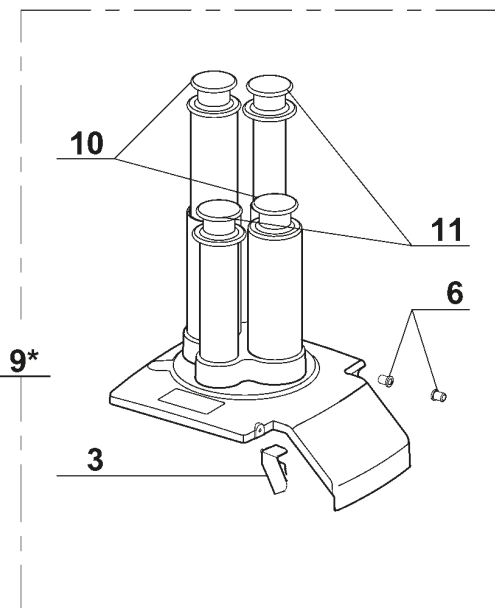
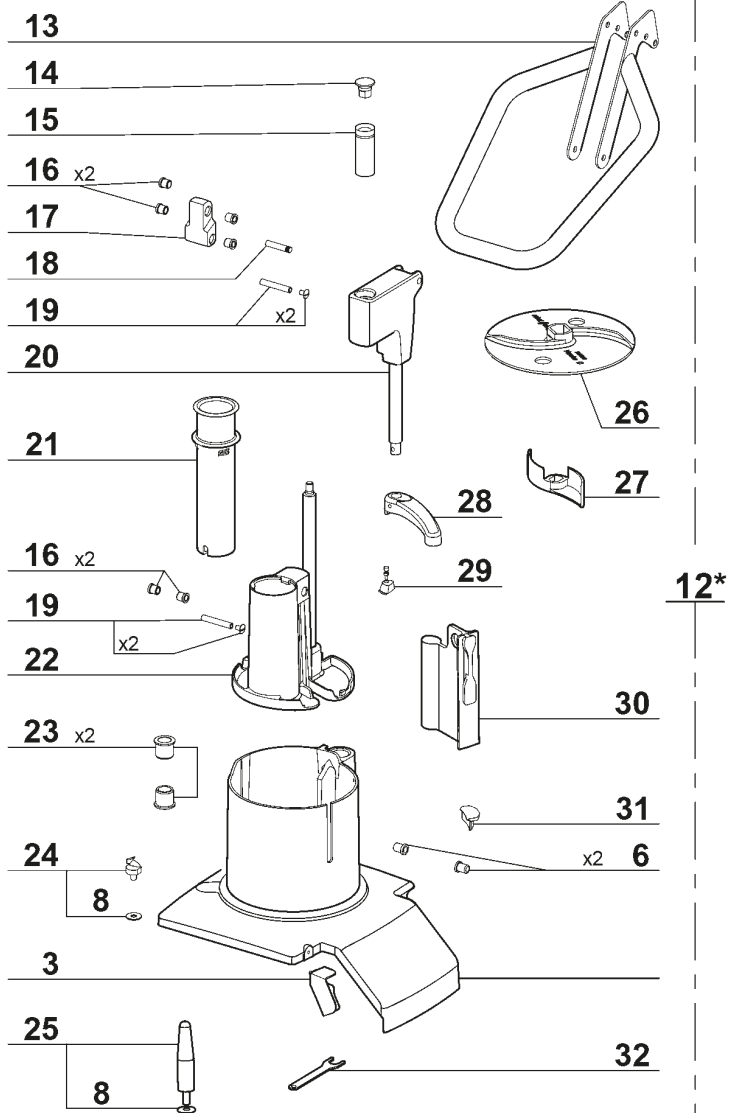
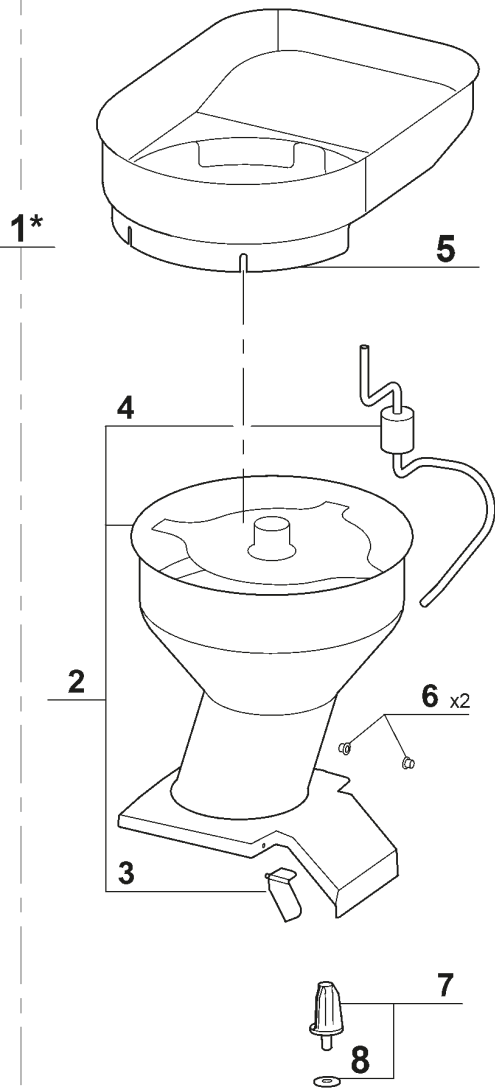

* Voir tarif machines / See export price list

38*

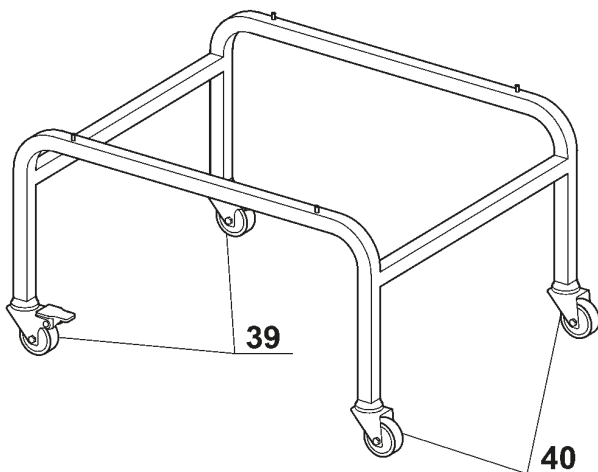

41*

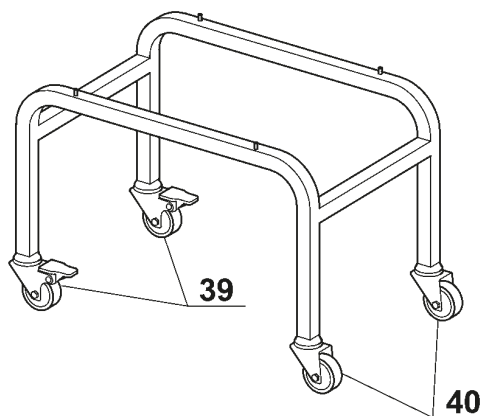

42*

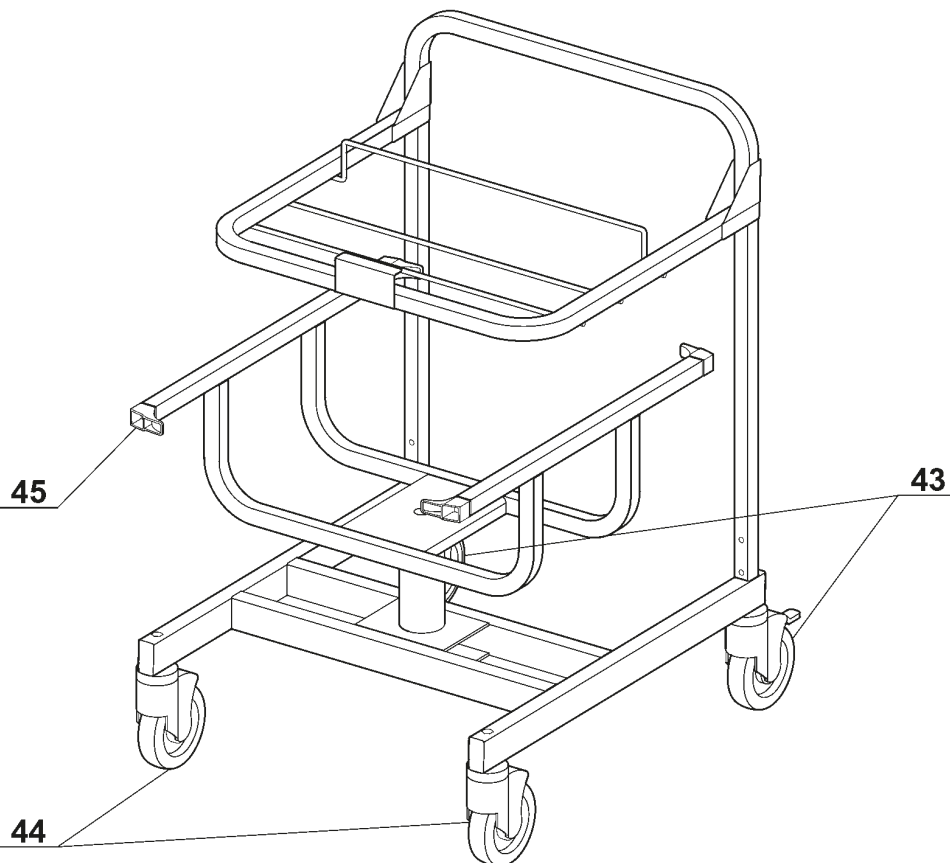

Index	Pièce / Part	Désignation	Description
1*	39 681	GOULOTTE AUTOMATIQUE INOX	STAINLESS STEEL BULK FEED HEAD
2	29 928	GOULOTTE	FEED HEAD
3	29 925	ENS. TAQUET D'ACCROCHAGE	LID LATCH ASSEMBLY
4	117 775	MANIVELLE	CRANK
5	117 774	PLATEAU D'ALIMENTATION	FEEDING TRAY
6	39 705	ENS. BAGUES EPAULEES (Qty=2)	SHOULDERED RING ASSEMBLY
7	117 777	AGITATEUR	AGITATOR
8	117 200	RONDELLE	ANTI-FRICTION WASHER
9*	28 162	GOULOTTE 4 TUBES DROITS	FEED HEAD 4 HOLE TUBES
10	101 538	POUSSOIR D70	PUSHER D70
11	101 539	POUSSOIR D50	PUSHER D50
12*	39 680	COUVERCLE COMPLET	COMPLETE FEED LEAD
13	39 684	POIGNEE CL60E	HANDLE CL60E
14	39 663	BUTEE DE POUSSOIR	PUSHER ABUTMENT
15	39 672	BAGUE DE GLISSEMENT	RING OF SLIDING
16	39 664	BAGUE EPAULEE (Qty=2)	SHOULDERED RINGS (Qty=2)
17	39 665	BIELLETTTE ARRIERE	BACK TIEROD
18	39 666	AXE PIVOT 8x40 MOL	AXLE 8x40
19	39 667	AXE PIVOT 8x50 (Qty=2)	AXLE 8x50 (Qty=2)
20	39 668	GUIDE POUSSOIR MONTE	PUSHER GUIDE ASSEMBLY
21	39 662	POUSSOIR CAROTTE	CARROTS PUSHER
22	39 669	POUSSOIR LEGUME MONTE	VEGETABLE PUSHER ASSEMBLY
23	39 670	PALIER EPAULE 15x25 (Qty=2)	SHOULDERED RINGS 18x25 (Qty=2)
24	29 692	ENSEMBLE EVIDOIR	GOUGE ASSEMBLY
25	29 156	ENS. CONE CHARGEMENT	FEEDING CONE ASSEMBLY
26	102 690	DISQUE EVACUATEUR	DISCHARGE PLATE
27	118 420	EVACUATEUR CHOUX	CABBAGE DISCHARGE PADDLE
28	39 671	PORTE AIMANT MONTE	MAGNET HOLDER ASSEMBLY
29	29 706	ENSEMBLE BUTEE POUSSOIR	PUSHER STOP ASSEMBLY
30	39 660	CLOISON AMOVIBLE	REMOVABLE WALL
31	117 321	BUTEE ANTI FRICTION	ANTI-FRICTION STOP
32	118 436	CLEF EVIDOIRE	GOUGE WRENCH
33*	28 157	GOULOTTE TUBE INCLINE	BIAIS FEED HEAD
34	101 535	INSERT DROIT D50	STRAIGHT INSERT D50
35	39 090	ENS. INSERT DROIT D50	STRAIGHT INSERT D50 ASSEMBLY
36	39 091	ENS. INSERT INCLINE D50	BIAIS INSERT D50 ASSEMBLY
37	101 537	INSERT INCLINE D50	BIAIS INSERT D50
38*	27 185	CHARIOT 2x1	TROLLEY 2x1
39	504 266	ROULETTE FREIN D60	BRAKE ROLLER D60
40	504 267	ROULETTE D60	ROLLER D60
41*	27 056	CHARIOT 1x1	TROLLEY 1x1
42*	49 066	CHARIOT ERGO MOBILE	TROLLEY
43	39 320	ROULETTE FREIN D100	BRAKE ROLLER D100
44	39 321	ROULETTE D100	ROLLER D100
45	39 329	ENS. BUTEE ROTATIVE (Qty=4)	ROTATABLE STOPPER ASSEMBLY (Qty=4)

CL 60 E

200-230-400V/50-60Hz - 415V/50Hz 3~

SCHEMA ELECTRIQUE

ELECTRIC DIAGRAM

ELEKTRISCHES SCHALTBILD



Important Vérifier que le fil d'adaptation à la tension de votre réseau est correctement positionné (voir tableau ci-contre).
Précautions Check that the wire which allows the adaptation to the supply voltage is on the right terminal (table in the margin).
Wichtiger Hinweis Unbedingt prüfen, ob der Draht zur Anpassung an die Spannung Ihres Stromnetzes Korrekt positioniert ist (Tafel Gegenüber).

Tension d'alimentation Supply voltage Stromspannung	Connexion Terminal Anschluss
200 V	200 (JP1)
220 -> 240 V	230 (JP2)
380 -> 415 V	400 (JP3)
440 V	440 (JP4)

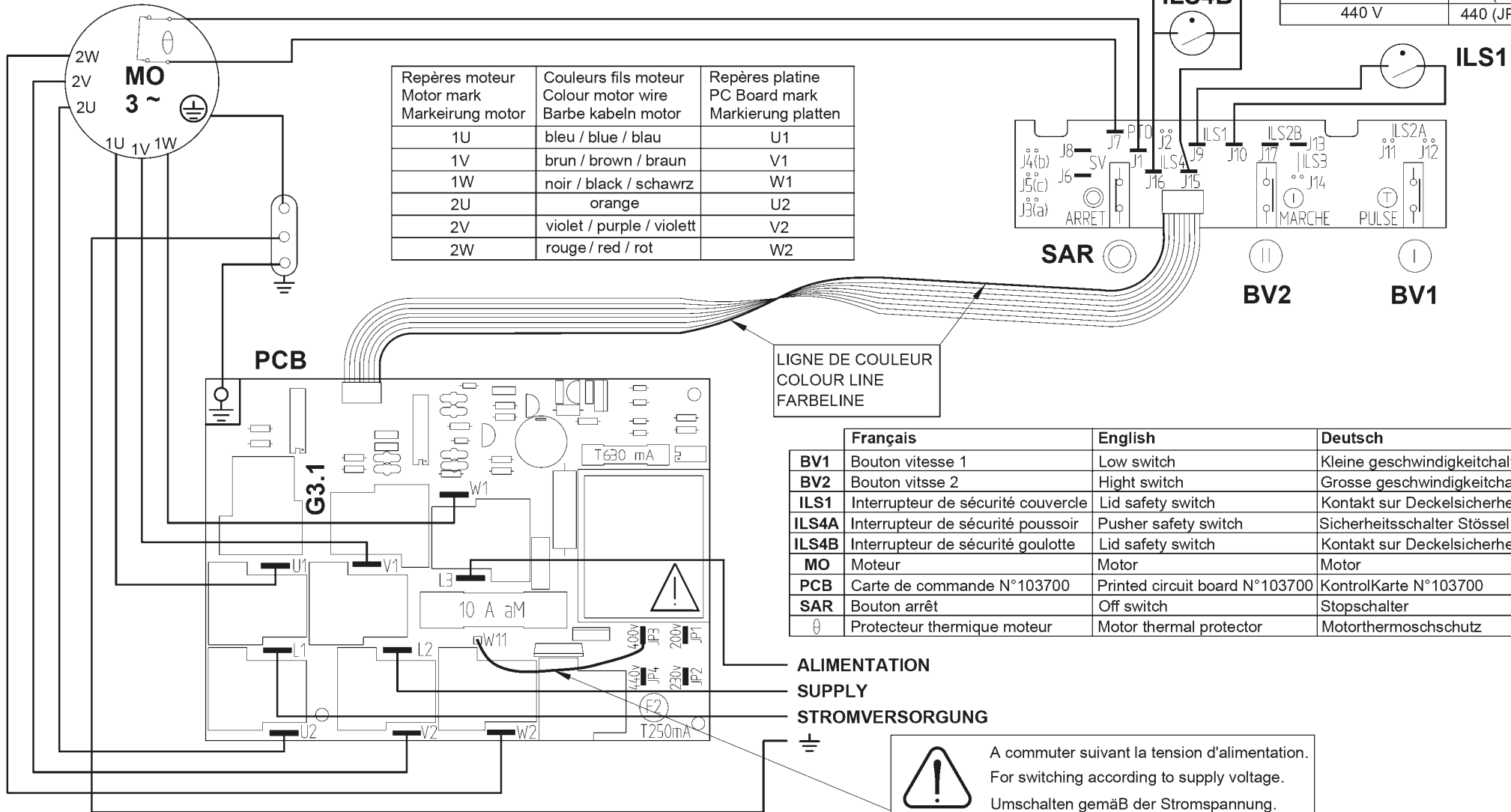

Repères moteur Motor mark Markierung motor	Couleurs fils moteur Colour motor wire Barbe kabeln motor	Repères platine PC Board mark Markierung platten
1U	bleu / blue / blau	U1
1V	brun / brown / braun	V1
1W	noir / black / schwarz	W1
2U	orange	U2
2V	violet / purple / violett	V2
2W	rouge / red / rot	W2

	Français	English	Deutsch
BV1	Bouton vitesse 1	Low switch	Kleine geschwindigkeitshalter
BV2	Bouton vitesse 2	High switch	Grosse geschwindigkeitshalter
ILS1	Interrupteur de sécurité couvercle	Lid safety switch	Kontakt sur Deckelsicherheit
ILS4A	Interrupteur de sécurité poussoir	Pusher safety switch	Sicherheitsschalter Stössel
ILS4B	Interrupteur de sécurité goulotte	Lid safety switch	Kontakt sur Deckelsicherheit
MO	Moteur	Motor	Motor
PCB	Carte de commande N°103700	Printed circuit board N°103700	KontrolKarte N°103700
SAR	Bouton arrêt	Off switch	Stopschalter
⊕	Protecteur thermique moteur	Motor thermal protector	Motorthermoschutz

ALIMENTATION
SUPPLY
STROMVERSORGUNG



A commuter suivant la tension d'alimentation.
 For switching according to supply voltage.
 Umschalten gemäß der Stromspannung.

CL 60 E 230/400V-50Hz 3~

ELECTRIC DIAGRAM

SCHEMA ELECTRIQUE

ELEKTRISCHES SCHALTBILD



Important : Vérifier que les fils d'adaptation à la tension de votre réseau sont correctement positionnés (voir tableau ci-contre).
Caution : Check that the wires which allow the adaptation to the supply voltage are on the right terminal (table in the margin).
Wichtiger Hinweis : Unbedingt prüfen, ob die Drähte zur Anpassung an die Spannung Ihres Stromnetzes Korrekt positioniert sind (Tafel Gegenüber).

Fil Wire Leitung	Connecté sur Connect on AnschlieBen auf	
	230V	400V
W11	JP2	JP3
C 1	C1/230V	C1/400V
C 2	C2/230V	C2/400V
C 3	C3/230V	C3/400V

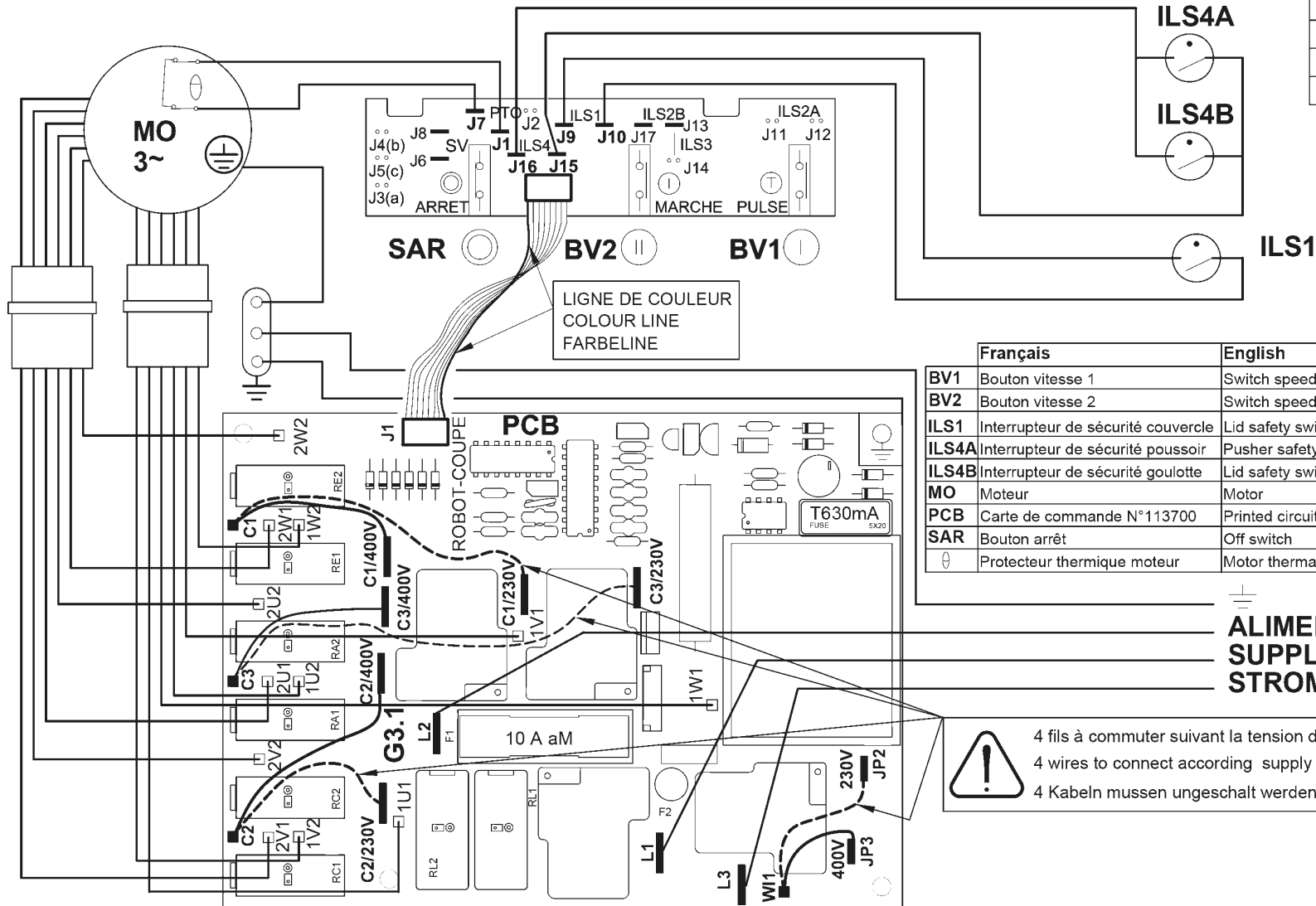

	Français	English	Deutsch
BV1	Bouton vitesse 1	Switch speed 1	Geschwindigkeitsschalter 1
BV2	Bouton vitesse 2	Switch speed 2	Geschwindigkeitsschalter 2
ILS1	Interrupteur de sécurité couvercle	Lid safety switch	Kontakt sur Deckelsicherheit
ILS4A	Interrupteur de sécurité poussoir	Pusher safety switch	Sicherheitsschalter Stössel
ILS4B	Interrupteur de sécurité goulotte	Lid safety switch	Kontakt sur Deckelsicherheit
MO	Moteur	Motor	Motor
PCB	Carte de commande N°113700	Printed circuit board N°113700	KontrolKarte N°113700
SAR	Bouton arrêt	Off switch	Stopschalter
⊕	Protecteur thermique moteur	Motor thermal protector	Motorthermoschutz

**ALIMENTATION
SUPPLY
STROMVERSORGUNG**



4 fils à commuter suivant la tension d'alimentation.
 4 wires to connect according supply voltage.
 4 Kabeln müssen ungeschalt werden entsprechend der Stromversorgung.

CL 60 D & E 230/400V - 50Hz - 3~

ATTENTION : Il y a 4 fils à connecter suivant la tension d'alimentation.

CAUTION : There are 4 wires to connect according to supply voltage.

230 V / 50 Hz / 3~

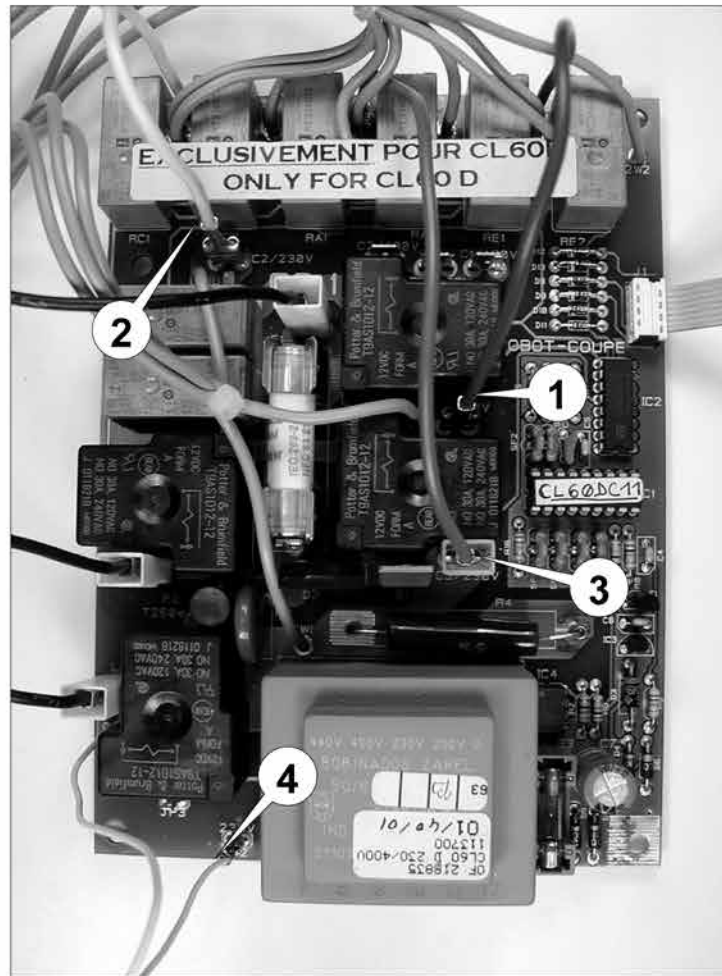

400 V / 50 Hz / 3~

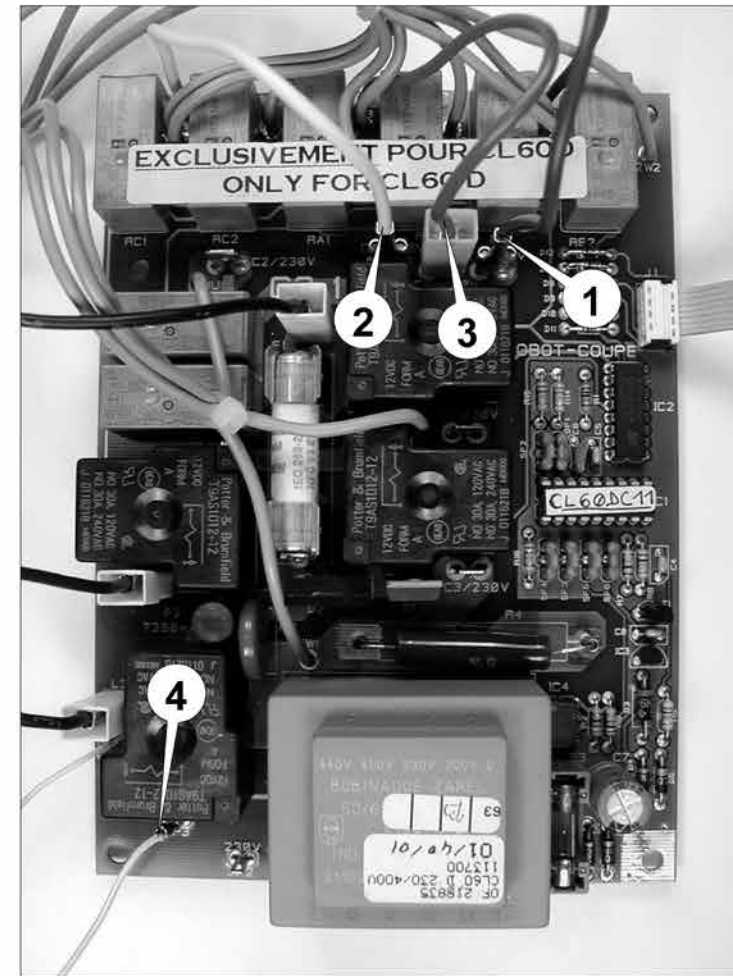

CL60E V.V. 200-240V/50-60Hz 1~

SCHEMA ELECTRIQUE

ELECTRIC DIAGRAM

ELEKTRISCHES SCHALTBILD

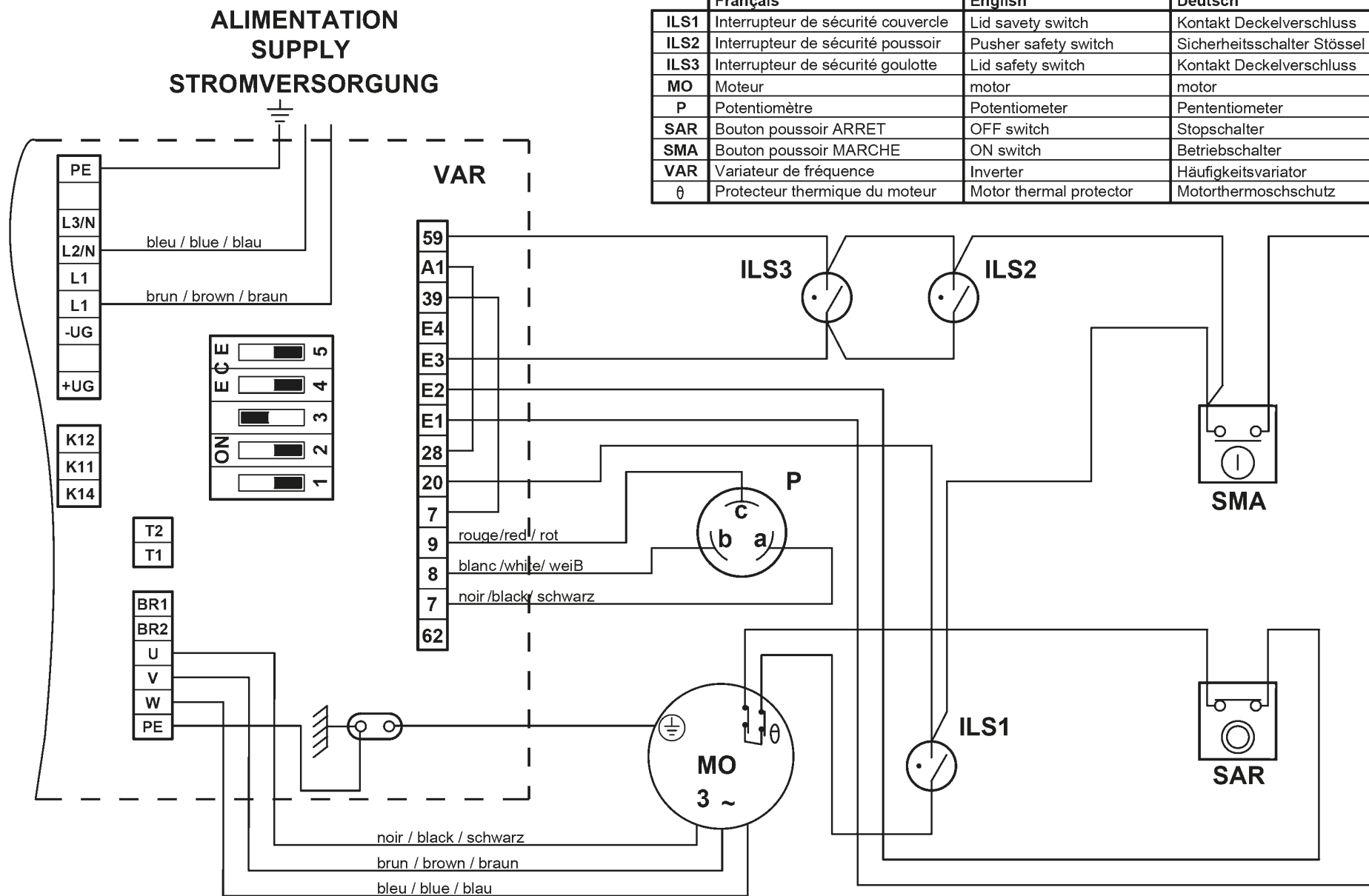



robot  coupe®

**Head Office, French,
Export and Marketing Department:**
48, rue des Vignerons
94305 Vincennes Cedex- France
Tel.: 01 43 98 88 15 - Fax: 01 43 74 36 26
Email: international@robot-coupe.com

Robot Coupe Australia Pty Ltd:
Unit 3/43 Herbert St
Artarmon NSW 2064 Australia
Tel.: (02) 9478 0300
Fax (02) 9460 7972
Email: orders@robotcoupe.com.au

Robot-Coupe U.K. LTD:
Fleming Way, Isleworth,
Middlesex TW7 6EU
Tel.: 020 8232 1800
Fax: 020 8568 4966
Email: sales@robotcoupe.co.uk