

# *robot coupe*®



**NEW**  
Register  
your product  
on line

**CL 40**

# www.robot-coupe.com

## @ Register your product on line

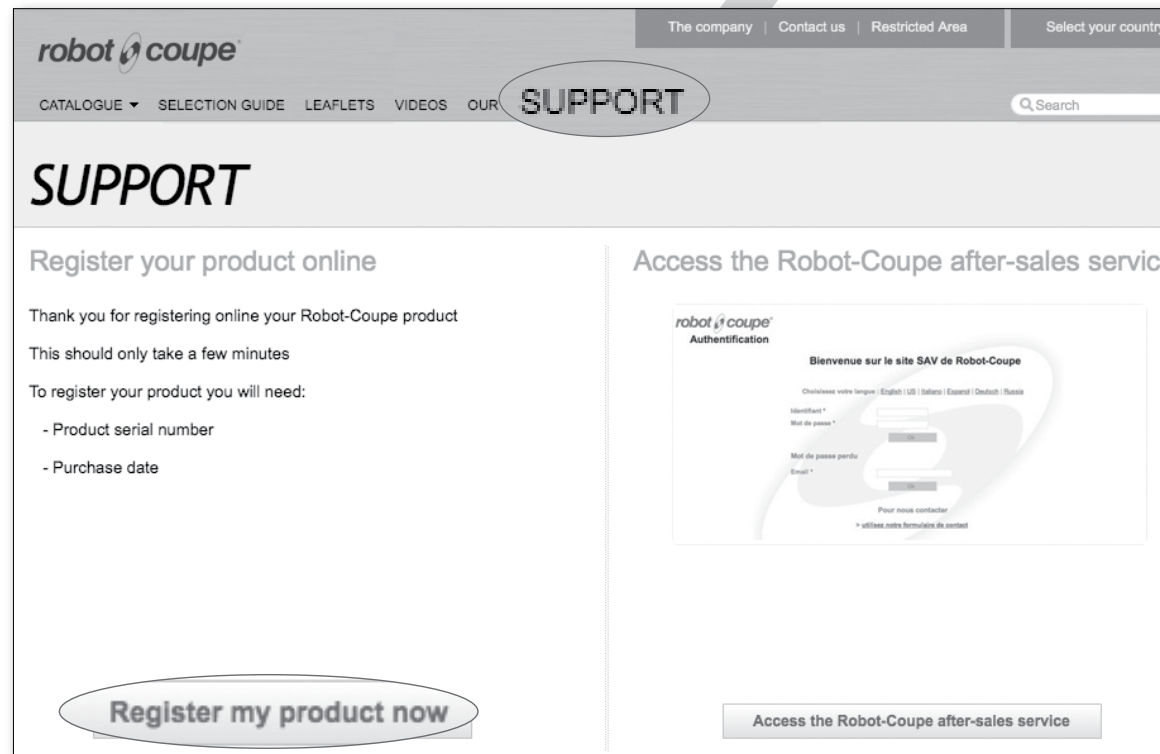

The screenshot shows the Robot-Coupe website's support page. At the top, there is a navigation bar with the company logo, links for 'The company', 'Contact us', 'Restricted Area', and 'Select your country...'. Below this is a secondary navigation bar with 'CATALOGUE', 'SELECTION GUIDE', 'LEAFLETS', 'VIDEOS', 'OUR SUPPORT', and a search bar. The main content area is titled 'SUPPORT' and is divided into two columns. The left column is titled 'Register your product online' and contains the following text: 'Thank you for registering online your Robot-Coupe product', 'This should only take a few minutes', and 'To register your product you will need:'. Below this is a list of requirements: '- Product serial number' and '- Purchase date'. At the bottom of this column is a button labeled 'Register my product now'. The right column is titled 'Access the Robot-Coupe after-sales service' and contains an image of an authentication page. The authentication page has the title 'robot coupe Authentification' and the subtitle 'Bienvenue sur le site SAV de Robot-Coupe'. It includes a language selection dropdown, fields for 'Identifiant \*' and 'Mot de passe \*', a 'Mot de passe perdu' link, and an 'Email \*' field. At the bottom of the authentication page is a link 'Pour nous contacter' and a note '» utiliser notre formulaire de contact'. At the bottom of the right column is a button labeled 'Access the Robot-Coupe after-sales service'.

# robot coupe®

# robot coupe®



## DECLARATION OF CONFORMITY

Declares that the machines identified by their type above, comply with:

- The essential requirements of the following European directives and with the corresponding national regulations:

- Directive «Machinery» 2006/42/EC,
- Directive «Low voltage» 2014/35/EU,
- Directive «Electromagnetic compatibility» 2014/30/EU,
- Regulation (EC) n°1935/2004 «Materials and articles intended to come into contact with food»,
- Regulation (EU) n°10/2011 «Plastic materials and articles intended to come into contact with food»,
- Directive «Reduction of Hazardous Substances (RoHS) 2002/95/EC,
- Directive «WEEE» 2012/19/EU,

- The requirements of the European harmonized standards and with the standards specifying the hygiene and safety requirements:

- EN ISO 12100: 2010: Safety of machinery – General principles for design,
- EN 60204-1 -2006: Safety of machinery – Electrical equipment of machines,
- EN 12852: Food Processors and Blenders,
- EN 1678-1998: Vegetable Cutting Machines,
- EN 454 + A1 2010-02: Blender-Mixers,
- EN 12853: Hand-held Blenders and Whisks (stick blenders),
- EN 14655: Bread Slicers,
- EN 13208: Vegetable Preparation Machines,
- EN 13621: Salad Spinners,
- EN 60529-2000: Degrees of protection,
  - IP 55 for the electrical controls,
  - IP 34 for the machines.

Montceau en Bourgogne on 4 March 2016

Alain NODET  
Industrial Director

# SUMMARY

## ■ WARRANTY

## ■ IMPORTANT WARNING

## ■ INTRODUCTION TO YOUR NEW VEGETABLE PREPARATION MACHINE CL 40

## ■ SWITCHING ON THE MACHINE

- Advice on electrical

## ■ ASSEMBLY

## ■ USES AND CHOICE OF DISCS

## ■ CLEANING

## ■ MAINTENANCE

- Motor seal
- Locking washer
- Blades
- Grating, julienne and ripple-cut discs

## ■ TECHNICAL SPECIFICATIONS

- Weight
- Dimensions
- Working height
- Noise level
- Electrical data

## ■ SAFETY

## ■ STANDARDS

## ■ TECHNICAL DATA

- Exploded views
- Electric and wiring diagrams

# ROBOT-COUCPE S.N.C., LIMITED WARRANTY

Your new ROBOT-COUCPE appliance is warranted to the original buyer for a period of one year from the date of sale if you bought it from ROBOT-COUCPE S.N.C.

If you bought your ROBOT-COUCPE product from a distributor your product is covered by your distributor's warranty (Please check with your distributor terms and conditions of the warranty).

The ROBOT-COUCPE S.N.C. limited warranty is against defects in material and/or workmanship.

## THE FOLLOWING ARE NOT COVERED BY THE ROBOT-COUCPE S.N.C. WARRANTY:

**1** - Damage caused by abuse, misuse, dropping, or other similar damage caused by or resulting from failure to follow assembly, operating, cleaning, user maintenance or storage instructions.

**2** - Labour to sharpen and/ or replacements for blades which have become blunt, chipped or worn after a normal or excessive period of use.

**3** - Materials or labour to replace or repair scratched, stained, chipped, pitted, dented or discoloured surfaces, blades, knives, attachments or accessories.

**4** - Any alteration, addition or repair that has not been carried out by the company or an approved service agency.

**5** - Transportation of the appliance to or from an approved service agency.

**6** - Labour charges to install or test new attachments or accessories (i.e., bowls, discs, blades, attachments) which have been arbitrarily replaced.

**7** - The cost of changing direction-of-rotation of three-phase electric motors (Installer is responsible).

**8** - SHIPPING DAMAGES. Visible and latent defects are the responsibility of the freight carrier. The consignee must inform the carrier and consignor immediately, or upon discovery in the case of latent defects.

**KEEP ALL ORIGINAL CONTAINERS AND PACKING MATERIALS FOR CARRIER INSPECTION.**

Neither ROBOT-COUCPE S.N.C. nor its affiliated companies or any of its distributors, directors, agents, employees, or insurers will be liable for indirect damage, losses, or expenses linked to the appliance or the inability to use it.

**The ROBOT-COUCPE S.N.C. warranty is given expressly and in lieu of all other warranties, expressed or implied, for merchantability and for fitness toward a particular purpose and constitutes the only warranty made by ROBOT-COUCPE S.N.C. France.**

# IMPORTANT WARNING



**WARNING:** In order to limit accidents such as electric shocks, personal injury or fire, and in order to limit material damage due to misuse of the appliance, please read these instructions carefully and follow them strictly. Reading the operating instructions will help you get to know your appliance and enable you to use the equipment correctly. Please read these instructions in their entirety and make sure that anyone else who may use the machine also reads them beforehand.

## UNPACKING

- Carefully remove the equipment from the packaging and take out all the boxes or packets containing attachments or specific items.
- **WARNING** - some of the tools are very sharp e.g. blade, discs... etc.

## INSTALLATION

- We recommend you to install your machine on a perfectly stable solid base.

## CONNECTION

- Always check that your mains supply corresponds to that indicated on the rating plate on the motor unit and that it can take the amperage.
- The machine must be earthed.

## HANDLING

- Always take care when handling the blades or discs - they are very sharp.

## ASSEMBLY PROCEDURES

- Follow the various assembly procedures carefully (see page 6) and make sure that all the attachments are correctly positioned.

## USE

- Never try to override the locking and safety systems.
- Never introduce any object into the container where the food is being processed.
- Never push the ingredients down with your hand.
- Do not overload the appliance.
- Never switch the appliance on while it is empty.

## CLEANING

- As a precaution, always unplug your appliance before cleaning it.
- Always clean the appliance and its attachments at the end of each cycle.
- Never place the motor unit in water.
- For parts made of aluminum alloys, use cleaning fluids suitable for aluminum.

- For plastic parts, do not use detergents that are too alkaline (i.e., containing too much caustic soda or ammonia...).
- Robot-Coupe can in no way be held responsible for the user's failure to follow the basic rules of cleaning and hygiene.

## MAINTENANCE

- Before opening the motor housing, it is absolutely vital to unplug the appliance.
- Check the seals and washers regularly and ensure that the safety devices are in good working order.
- It is particularly important to maintain and check the attachments since certain ingredients contain corrosive agents e.g. citric acid.
- Never operate the appliance if the power cord or plug has been damaged in any way or if the appliance fails to work properly or has been damaged in any way.
- Do not hesitate to contact your local Maintenance Department if something appears to be wrong.

## INTRODUCTION TO YOUR NEW VEGETABLE PREPARATION MACHINE CL 40

The CL 40 is perfectly geared to professional needs. It can perform any number of tasks, which you will gradually discover as you use it.

The CL 40 is equipped with a **stainless steel vegetable bowl** and a lid made in ABS (automatic restart of the machine with the pusher).

The CL 40 is equipped with a **range of 28 discs** for making slices, grating, julienne, dicing and French fries.

Thanks to its simple design, all components requiring frequent handling for maintenance or cleaning can be fitted and removed in a trice

To make things easier for you, this manual gives a breakdown of all the various fitting operations.

This manual contains important information designed to help the user get the most out of his or her CL 40 vegetable preparation device.

We place special emphasis on those actions which cause the machine to stop.

**We therefore recommend that you read it carefully before using your machine.**

We have also included a few examples to help you get the feel of your new machine and appreciate its numerous advantages.

## SWITCHING ON THE MACHINE

### • ADVICE ON ELECTRICAL CONNECTIONS

Before plugging in, check that your power supply corresponds to that indicated on the machine's identification plate.



## WARNING

**This appliance must be plugged into an earthed socket (risk of electrocution).**

The machine comes with a single phase plug connected to a power cord.

The CL 40 are fitted with various types of motors :

230 V / 50 Hz / 1

120 V / 60 Hz / 1

220 V / 60 Hz / 1



2) Turn the bowl to the right until the motor base connectors are securely positioned in their sockets.

3) Slot the black or white plastic ejection tool onto the drive shaft, checking that it is correctly positioned at the bottom of the bowl.



## ASSEMBLY

The vegetable preparation machine consists of two detachable parts: the stainless steel vegetable preparation bowl and the lid.



1) With the motor base facing you, fit the bowl onto the motor base; the ejection chute should be on your right.

### Two ejection tools:

The CL 40 is supplied with two ejection tools. The **white** ejector has been specially designed to cope with cabbage. For all other vegetables, use the **black** plastic ejector disc.



Cabbage ejector



Ejector disc

2) Turn the bowl to the right until the motor base connectors are securely positioned in their sockets.



b) **If you have chosen the dicing equipment:** i.e. a grid and slicing disc.

**You must only use the 8-mm, 10-mm or 12-mm aluminium slicing discs with the dicing grids.**

Make sure the dicing grid is correctly positioned in the veg prep bowl (see box opposite).

Check that the notch on the edge of the dicing grid is correctly positioned over the tab on the bowl (see marking on grid).



Next fit the appropriate slicing disc and screw the slicer on the motorshaft with the butterfly nut.



## WARNING

### • INSTALLING THE DICING GRID:

These grids can be positioned in two different ways depending on the type of hopper used in order to avoid any false starts.

#### • Position 1: Using the large hopper.

In this case, the dicing grid should be positioned so that its blades are vertically aligned with the hopper. (You must be able to see the grid blades when looking into the hopper.)

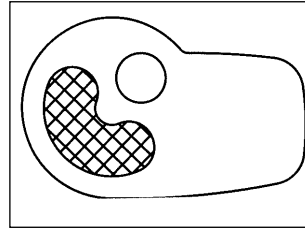

#### • Position 2: Using the cylindrical hopper.

In this case, the grid must be positioned so that the blades are vertically aligned with the tube. (You must be able to see the grid blades when looking into the tube.)

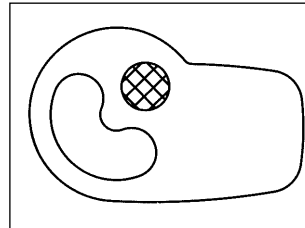

### c) **If you want to use the French fries potatoes cutting equipment:**

**This equipment comprises a French fries grid and a special French fries slicing disc.**

Position the French fries grid in the vegetable preparation bowl. Check that it is correctly positioned with the French fries plate positioned at the outlet.



Next fit the appropriate slicing disc and screw the slicer on the motorshaft with the butterfly nut.

5) Place the lid on the bowl and rotate to the right until the lid clicks, to form an extension of the bowl.



## USES AND CHOICE OF DISCS

The vegetable preparation machine consists of two hoppers:

- **One large hopper** for cutting vegetables such as cabbage, celeriac, etc...
- **One cylindrical hopper** for long vegetables and high-precision cutting.







For optimum cutting, use this section as a guide.

### HOW TO USE THE LARGE HOPPER

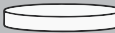
- Raise the lever and release the hopper opening.
- Fill hopper with vegetables.
- Replace the lever at the base of the hopper.
- Start to press the lever, switch on machine and maintain pressure until there are no vegetables left in the hopper.

### HOW TO USE THE CYLINDRICAL HOPPER

- Fill hopper with vegetables.
- Start to press the button and switch on machine.
- Maintain pressure until all the vegetables have been chopped up.

SLICERS			
S 1	carrot / cabbage / cucumber / onion / potato / leek		
S 2 / S 3	lemon / carrot / mushroom / cabbage / potato / cucumber / zucchini / onion / leek / bell pepper		
S 4 / S 5	eggplant / beet root / carrot / mushroom / cucumber / bell pepper / radish / lettuce / potato / leek / tomato		
S 6	eggplant / beet root / carrot / mushroom / cucumber / bell pepper / radish / lettuce / potato / leek		
RIPPLE CUT SLICER			
RCS 2	beet root / potato / carrot		
GRATERS			
G 1,5	celeriac / cheese	G 9	cabbage / cheese
G 2	carrot / celeriac / cheese		Parmesan / chocolate
G 3	carrot		Radish 0.7 mm
G 6	cabbage / cheese		Radish 1 mm
JULIENNE			
J 2x2	carrot / celeriac / potato		
J 2x4	carrot / beet root / zucchini / potato		
J 2x6	carrot / beet root / zucchini / potato		
J 4x4	eggplant / beet root / zucchini / potato		
J 6x6	eggplant / beet root / celeriac / zucchini / potato		
J 8x8	celeriac / potato		
DICE			
D 8x8	potato / carrot / zucchini / beet root / turnip		
D 10x10	potato / carrot / zucchini / beet root / turnip		
FRENCH FRIES			
F 8x8	potato		
F 10x10	potato		

## CLEANING



### WARNING

**As a precaution, always unplug your appliance before cleaning it (risk of electrocution).**

Remove each of the part, i.e.: the lid, disc, sling plate and bowl and clean.

All the parts are dishwasher safe, providing you use the right amount of detergent and choose one that is suitable for plastics and stainless steel. It should, however, be noted that cleaning parts in a dishwasher shortens their lifespan.

We recommend that you periodically remove any food residue that may have accumulated under the blades of the slicing discs of the french fry and dicing kits.

To do this, unscrew the blades using a flat-head screwdriver.

**Never immerse the motor base in water. Clean using a damp cloth or sponge.**



### IMPORTANT

**Check that your detergent is suitable for cleaning plastic parts. Some washing agents are too alkaline (e.g. high levels of caustic soda or ammonia) and totally incompatible with certain types of plastic, causing them to deteriorate rapidly.**

## MAINTENANCE

### • MOTOR SEAL

The motor seal on the shaft should be lubricated regularly using a food safe lubricant.

In order to keep the motor completely watertight, it is advisable to check the motor seal regularly for wear and tear and replace if necessary.

The motor seal can be easily replaced without having to remove the motor, so we strongly advise you to ensure that is in good condition.

### • LOCKING WASHER

To ensure that your appliance continues to run smoothly, we recommend that you regularly check the locking washer for wear and tear.

If the washer becomes worn, we therefore advise you to replace it.

### • BLADES

The blades of the slicing discs of the dicing and french fry kits are wearing parts that must be replaced from time to time, in order to maintain optimum cutting quality.

### • GRATING, JULIENNE AND RIPPLE-CUT DISCS

The grating, julienne and ripple-cut discs gradually become blunt and should be replaced from time to time to maintain optimum cutting quality.

## TECHNICAL SPECIFICATIONS

### • WEIGHT

	Net	Gross
CL 40 (without disc)	16 kg	18 kg
Disc	0.5 kg	0.6 kg

### • DIMENSIONS (in mm)

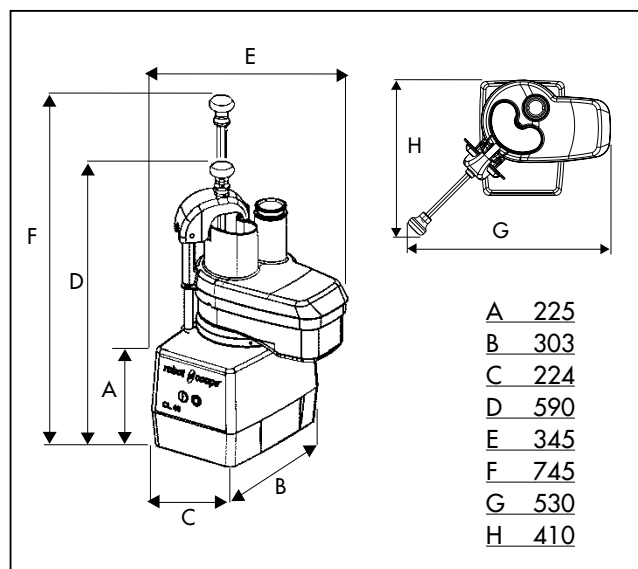

### • WORKING HEIGHT

We recommend that you position the CL 40 on a stable worktop so that the upper edge of the large feed hopper is at a height of between 1.20 m and 1.30 m.

### • NOISE LEVEL

The equivalent continuous sound level when the CL 40 is operating on no-load is less than 70 dB (A).

### • ELECTRICAL DATA

Single phase machine

Motor	Speed (rpm)	Intensity (Amp)
230 V/50Hz	500	5.4
240 V/50Hz	500	5.4
120 V/60Hz	600	12.0
220 V/60Hz	600	5.4

- Power shown on data plate.

## SAFETY

The CL 40 is fitted with a magnetic safety device and motor braking system.

As soon as you open the lid, the motor stops.

To restart the machine, simply close the lid and press the green switch.

**! WARNING**

**The discs are extremely sharp. Handle with care.**

The CL 40 is fitted with a **thermal cut-out** which automatically stops the motor if the machine is left on for too long or overloaded.

If this happens, allow the machine to cool completely before restarting.



## REMEMBER

**Never try to override the locking and safety systems.**

**Never insert an object into the container where the food is being processed.**

**Never push the ingredients down with your hand.**

**Do not overload the appliance.**

## STANDARDS

Consult the declaration of compliance on page 3.

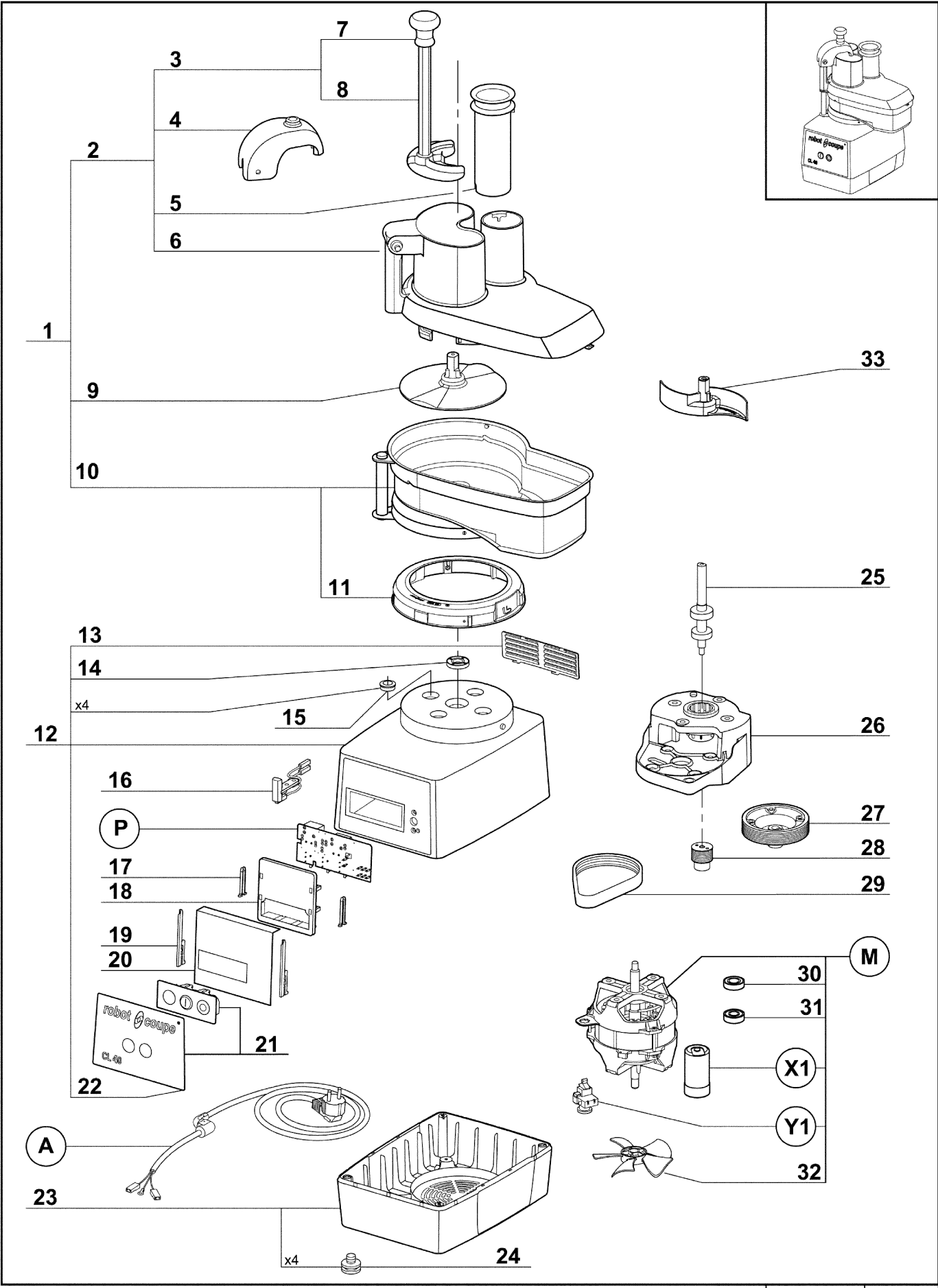
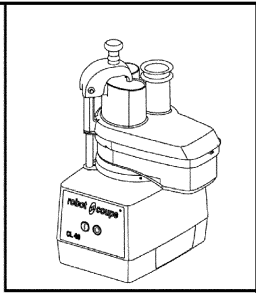







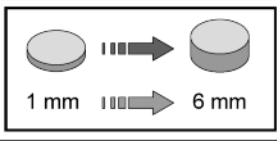
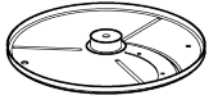

Index	Pièce / Part	Désignation	Description
1	27 400	ACCESSOIRE COUPE-LEGUMES	VEGETABLE SLICER ATTACHMENT
2	49 033	TETE COUPE-LEGUMES COMPLETE	VEGETABLE SLICER HEAD
3	29 880	ENS POUSSOIR	PUSHER ASSEMBLY
4	49 036	GUIDE POUSSOIR	PUSHER GUIDE
5	118 324	POUSSOIR CAROTTES	ROUND PUSHER
6	49 037	COUVERCLE COUPE-LEGUMES	VEGETABLE SLICER LID
7	117 452	POIGNEE	HANDLE KNOB
8	103 703	POUSSOIR LEGUMES	VEGETABLE PUSHER
9	104 921	DISQUE EVACUATEUR	SLING PLATE
10	49 034	CUVE COUPE-LEGUMES	VEGETABLE SLICER BOWL
11	49 035	ENS RONDELLE D'ACCROCHAGE	LOCKING WASHER ASSEMBLY
12	49 029	ENS SUPPORT MOTEUR	MOTOR SUPPORT ASSEMBLY
13	104 122	GRILLE VENTILATION	VENT COVER
14	501 010	BAGUE ETANCHEITE	MOTOR SEAL
15	104 070	CAPSULE CACHE VIS	BOLT COVER
16	29 356	ILS COMPLET COUPE-LEGUMES	VEGETABLE REED SWITCH
17	102 913	CLAVETTE PLASTRON	PANEL KEY
18	102 911	SUPPORT PLATINE	PCB SUPPORT
19	117 703	CLAVETTE FIXE PLATINE	PCB KEY
20	104 131	PROTEGE PLATINE	PCB PROTECT
21	49 031	ENS TABLEAU COMMANDE	SWITCH ASSEMBLY
22	49 032	PLAQUE FRONTALE	FRONT PLATE
23	39 112	ENS SOCLE	BASE ASSEMBLY
24	39 928	PIEDS (x4)	FEET (x4)
25	29 604	ENS AXE TRANSMISSION	TRANSMISSION SHAFT ASSEMBLY
26	104 125	SUPPORT TRANSMISSION	TRANSMISSION SUPPORT
27	102 923	POULIE RECEPTRICE	LARGE PULLEY
28	102 924	POULIE MOTRICE	SMALL PULLEY
29	503 940	COURROIE	BELT
30	504 229	ROULEMENT MOTEUR SUPERIEUR 6002 2RS	UPPER BALL-BEARING 6002 2RS
31	600 457	ROULEMENT MOTEUR INFERIEUR 6201 2RS	LOWER BALL-BEARING 6201 2RS
32	117 610	VENTILATEUR MOTEUR	MOTOR FAN
33	108 173	EVACUATEUR CHOUX	CABBAGE EJECTOR

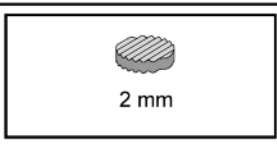
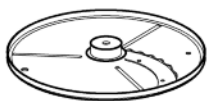
Index	Désignation	Description
<b>A</b>	CABLE D'ALIMENTATION	POWER CORD
<b>M</b>	MOTEUR	MOTOR
<b>P</b>	CARTE DE COMMANDE	CONTROL BOARD
<b>X</b>	CONDENSATEUR DE DEMARRAGE	STARTING CAPACITOR
<b>Y</b>	RELAIS DEMARRAGE MOTEUR	MOTOR STARTING RELAY

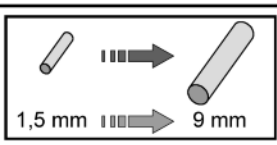
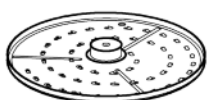
Machine	Voltage	A	M	P	X1	Y1
2 149 Pack 2D UK	240/50/1	504 275	3 122	103 691	600 018	500 289
24 571 UK						
2 148 Pack 2D AUST		504 278				
24 572 AUST						
24 577 DK	230/50/1	504 276				
24 576 CH		504 292				
2 008 Pack 4D SWE		504 274				
2 150 Pack 6D SWE						
24 570	220/60/1	504 275	3 195	600 018	504 674	
24 584 SAU		39 604				
24 594 BRA						504 274
24 574						
24 575	120/60/1	504 277	3 125	103 690	603 669	500 296

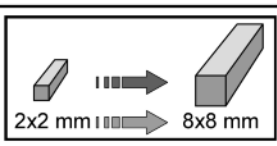
R101A, R201, R201 Ultra, R211, R211 Ultra, R201E, R201 Ultra E,  
R301\*\*, R301 Ultra\*\*, R302, R302 Plus, R401\*\*, R402\*\*, R402 VV\*\*, CL40\*\*

	 <p>1 mm → 6 mm</p>	<p><b>EMINCEURS / SLICERS</b></p>		<p><b>777 110</b></p>
<p>1 mm 2 mm 3 mm 4 mm 5 mm 6 mm</p>				<p>1* 2* 3* 4* 5* 6*</p>
	 <p>2 mm</p>	<p><b>ONDULÉS / WAVED CUT</b></p>		<p><b>777 110</b></p>
<p>POMME ONDULEES 2 mm / RIPPLE CUT 2 mm</p>				<p>7*</p>
	 <p>1,5 mm → 9 mm</p>	<p><b>RAPEURS / GRATERS</b></p>		<p><b>777 120</b></p>
<p>1,5 mm 2 mm 3 mm 6 mm 9 mm PARMESAN / PARMESAN POMME DE TERRE / POTATOES RADIS 0,7 mm / RADISH 0,7 mm RADIS 1 mm / RADISH 1 mm RADIS 1,3 mm / RADISH 1,3 mm 1,5 mm (POUR CL 40 / FOR CL40) 2 mm (POUR CL 40 / FOR CL40) 3 mm (POUR CL 40 / FOR CL40)</p>				<p>8* 9* 10* 11* 12* 13* 14* 15* 16* 17* 18* 19* 20*</p>
	 <p>2x2 mm → 8x8 mm</p>	<p><b>BATONNETS / JULIENNE</b></p>		<p><b>777 130</b></p>
<p>2 x 2 mm 2 x 4 mm 2 x 6 mm 4 x 4 mm 6 x 6 mm 8 x 8 mm</p>				<p>21* 22* 23* 24* 25* 26*</p>

R302, R302 Plus, R402\*\*, R402 VV\*\*, CL 40\*\*

## EQUIPEMENT MACEDOINE / DICING KIT

777 140

		8x8x8 mm	10x10x10 mm	12x12x12 mm
	<b>A</b>	27*	28*	29*
	<b>B</b>	30	31	32
	<b>C</b>	33	34	35
	<b>D</b>	36	36	36
	<b>E</b>	37	37	37

## D-CLEAN KIT

777 145

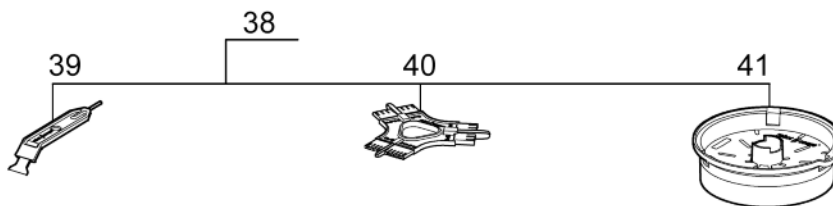

## EQUIPEMENT FRITES / FRENCH FRIES KIT

777 150

		8x8 mm	10x10 mm
	<b>D</b>	36	36
	<b>F</b>	42*	43*
	<b>G</b>	44	45
	<b>H</b>	46	47
	<b>I</b>	48	49

## ACCESSOIRES / ACCESSORIES



Index	Pièce / Part	Désignation	Description
1*	*27 051	EMINCEUR 1 mm	SLICER 1 mm
2*	*27 555	EMINCEUR 2 mm	SLICER 2 mm
3*	*27 086	EMINCEUR 3 mm	SLICER 3 mm
4*	*27 566	EMINCEUR 4 mm	SLICER 4 mm
5*	*27 087	EMINCEUR 5 mm	SLICER 5 mm
6*	*27 786	EMINCEUR 6 mm	SLICER 6 mm
7*	*27 621	POMPE ONDULEES 2 mm	RIPPLE CUT 2 mm
8*	*27 588	RAPEUR 1,5 mm	GRATER 1,5 mm
9*	*27 577	RAPEUR 2 mm	GRATER 2 mm
10*	*27 511	RAPEUR 3 mm	GRATER 3 mm
11*	*27 046	RAPEUR 6 mm	GRATER 6 mm
12*	*27 632	RAPEUR 9 mm	GRATER 9 mm
13*	*27 764	PARMESAN	PARMESAN
14*	*27 191	POMME DE TERRE	POTATOES
15*	*27 078	RADIS 0,7 mm	RADISH 0,7 mm
16*	*27 079	RADIS 1 mm	RADISH 1 mm
17*	*27 130	RADIS 1,3 mm	RADISH 1,3 mm
18*	*27 148	RAPEUR 1,5 mm POUR CL40	GRATER 1,5 mm FOR CL40
19*	*27 149	RAPEUR 2 mm POUR CL40	GRATER 2 mm FOR CL40
20*	*27 150	RAPEUR 3 mm POUR CL40	GRATER 3 mm FOR CL40
21*	*27 599	BATONNET 2X2 mm	JULIENNE 2X2 mm
22*	*27 080	BATONNET 2X4 mm	JULIENNE 2X4 mm
23*	*27 081	BATONNET 2X6 mm	JULIENNE 2X6 mm
24*	*27 047	BATONNET 4X4 mm	JULIENNE 4X4 mm
25*	*27 610	BATONNET 6X6 mm	JULIENNE 6X6 mm
26*	*27 048	BATONNET 8X8 mm	JULIENNE 8X8 mm
27*	*27 113	EQUIPEMENT MACEDOINE 8X8 mm	DICING KIT 8X8 mm
28*	*27 114	EQUIPEMENT MACEDOINE 10X10 mm	DICING KIT 10X10 mm
29*	*27 298	EQUIPEMENT MACEDOINE 12X12 mm	DICING KIT 12X12 mm
30	29 333	EMINCEUR MACEDOINE 8 mm	DICING SLICER 8 mm
31	29 334	EMINCEUR MACEDOINE 10 mm	DICING SLICER 10 mm
32	39 284	EMINCEUR MACEDOINE 12 mm	DICING SLICER 12 mm
33	102 064	GRILLE MACEDOINE 8 mm	DICING GRID 8 mm
34	102 065	GRILLE MACEDOINE 10 mm	DICING GRID 10 mm
35	105 226	GRILLE MACEDOINE 12 mm	DICING GRID 12 mm
36	39 933	ENSEMBLE VIS DE BLOCAGE	LOCKING SCREW ASSEMBLY
37	39 935	ENSEMBLE LAME + VIS	BLADE + SCREWS ASSEMBLY
38	39 881	D-CLEAN KIT	D-CLEANING KIT
39	39 883	OUTIL RACLEUR	SCRAPER TOOL
40	39 882	OUTIL DE NETTOYAGE	CLEANING TOOL
41	39 884	SUPPORT GRILLE	GRID HOLDER
42*	*27 116	EQUIPEMENT FRITES 8 mm	FRENCH FRIES KIT 8 mm
43*	*27 117	EQUIPEMENT FRITES 10 mm	FRENCH FRIES KIT 10 mm
44	29 343	EMINCEUR FRITES 8 mm	FRENCH FRIES SLICER 8 mm
45	29 344	EMINCEUR FRITES 10 mm	FRENCH FRIES SLICER 10 mm
46	102 066	GRILLE FRITES 8 mm	FRENCH FRIES GRID 8 mm
47	102 067	GRILLE FRITES 10 mm	FRENCH FRIES GRID 10 mm
48	39 936	ENSEMBLE LAME + VIS	BLADE + SCREWS ASSEMBLY
49	39 937	ENSEMBLE LAME + VIS	BLADE + SCREWS ASSEMBLY
50*	*27 019	CASIER DE RANGEMENT 6 DISQUES	STORAGE LOCKER 6 DISC
51	502 579	PIERRE A AFFUTER	HONING STONE





---

**robot coupe**®

**Head Office, French,  
Export and Marketing Department:**  
48, rue des Vignerons  
94305 Vincennes Cedex- France  
Tel.: 01 43 98 88 15 - Fax: 01 43 74 36 26  
Email: international@robot-coupe.com

**Robot Coupe Australia Pty Ltd:**  
Unit 3/43 Herbert St  
Artarmon NSW 2064 Australia  
T (02) 9478 0300  
F (02) 9460 7972  
Email: orders@robotcoupe.com.au

**Robot-Coupe U.K. LTD:**  
Fleming Way, Isleworth,  
Middlesex TW7 6EU  
Tel.: 020 8232 1800  
Fax: 020 8568 4966  
Email: sales@robotcoupe.co.uk

**[www.robot-coupe.com](http://www.robot-coupe.com)**