

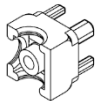







Instruction Manual

Food Bar Trolleys and Panels

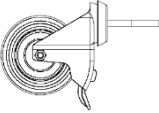
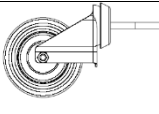

ET22, ETP22	Version 2
ET23, ETP23	Version 2
ET24, ETP24	Version 2
ET25, ETP25	Version 2
ET26, ETP26	Version 2

Parts No.'s/Contents	ET22	ET23	ET24	ET25	ET26	Diagrams
Pre Assembled bag Packed in castor box	1	1	1	1	1	 <p>4 x DC0103</p>  <p>4 x DC0104</p>  <p>8 x PC0326</p>
4 x MS0427- 455mm Vertical Frame (pre-assembled) 4 x DC0103 4 x DC0104 4 x MC0761	4	4	4	4	4	
4 x MS0428- 504.5mm Short Horizontal Frame (pre-assembled) 8 x DC0105 8 x MC0084	4	4	4	4	4	
4 x MS0390-MS0394 Long Horizontal Frame (pre-assembled) 8 x DC0105 8 x MC0084	4	4	4	4	4	
SS2131 Small Shelf Panel	2	2	2	2	2	
SS2130 Large Shelf Panel	0	1	2	3	4	
MC0151 Locking Castors	2	2	2	2	2	
MC0150 Plain Castors	2	2	2	2	2	
5mm Allen Key Packed in castor box	1	1	1	1	1	

Note: Some parts are pre-assembled.

INSTALLATION

Remove all the packaging materials and tape, as well as any protective plastic from the unit. Clean off any glue residue left over from the protective plastic using citrus cleaner.

TOOLS

To assemble the trolley the following tools are required.

5mm Allen key. (Supplied in kit)

Rubber or wooden mallet. A metal hammer and block of wood may be used if these are not available.

Please note: If you use a metal hammer, place the block of wood on the metal parts and strike the wood to prevent damage to the metal parts.

TROLLEY ASSEMBLY

1. Separate the frame parts as shown below. Note that all horizontal parts will have joiner fittings pre-assembled into each end.

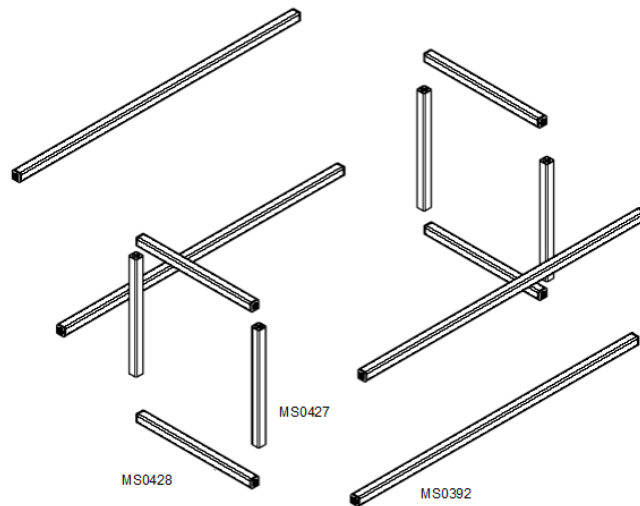

2. Get the following frame parts first and arrange them on the floor as shown. This step will assemble one corner of the trolley.

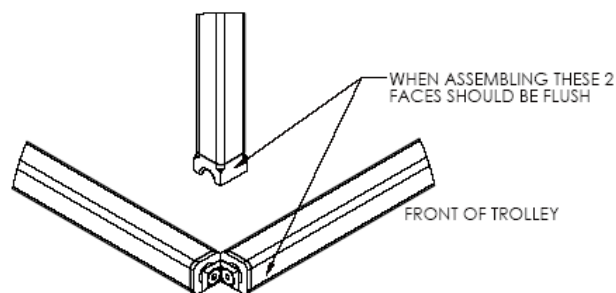

- a. One short horizontal frame (504.5mm)
- b. One long horizontal frame (length varies depending on the trolley size)
- c. One vertical frame (455mm)
 - i. Insert one of the DC0103 joiners into the plain end of this frame as shown. Use the mallet to tap the joiner into position.
- d. Assemble the three frames together as shown.

3. Assemble one of the DC0104 joiner covers and one of the PC0326 blanking plugs as shown.
 - a. Don't screw these together yet.

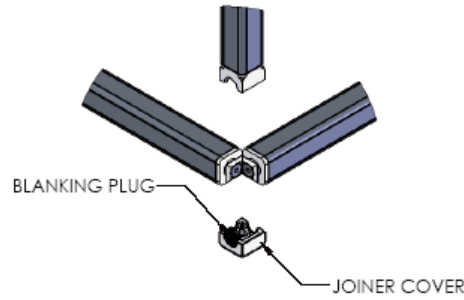

4. Repeat step 3 for the remaining corners.

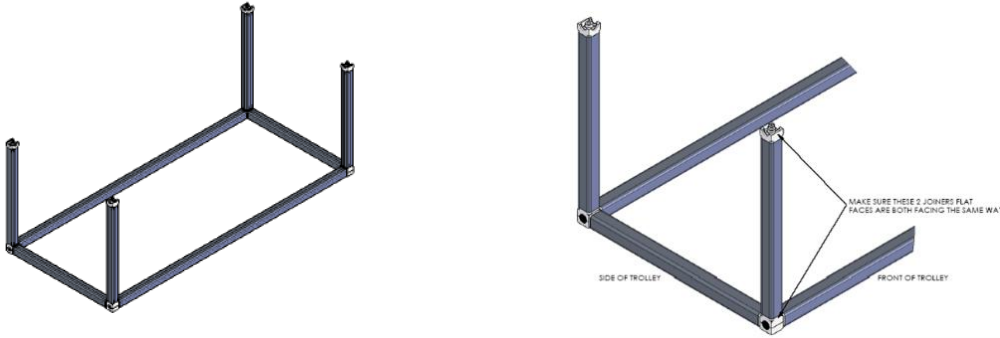

5. Assemble to remaining horizontal frames, joiner covers and banking plugs to the top of the assembled frame in the same manner as steps 3 and 4.
6. Assemble the castors onto each corner. Use the Allen key to tighten all the screws.
 - a. The screws will cut their own thread as they are screwed into the frame.
 - b. Two of the castors include a locking device these should be assembled on one long side of the trolley.

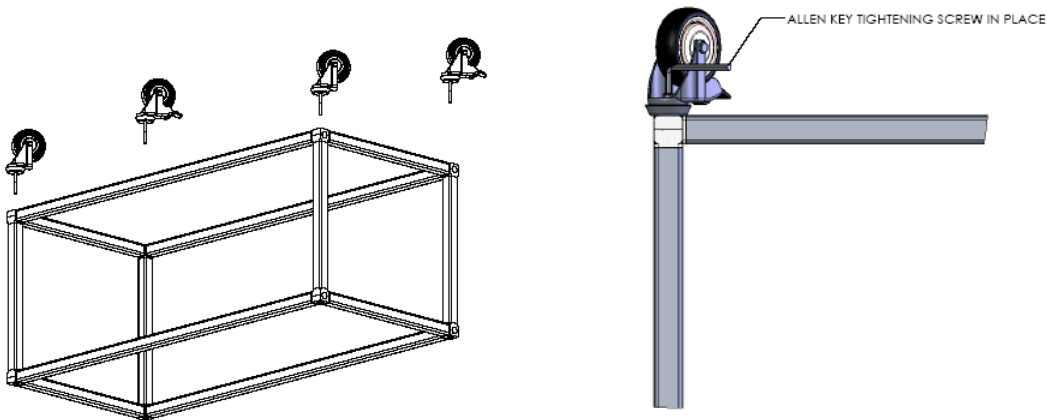

7. Flip the trolley over carefully, and insert the screws into the top joiner covers, and tighten. Again, the screws will cut their own thread as they are screwed into the frame.

8. Your trolley frame should now be tightly secured together and resemble the diagram below.



PANEL INSTALLATION

Size	ET Series panels		ETP Series panels		
	Shelf Outer Panels	Shelf Centre Panels	End Panels	Front Outer Panels	Front Centre Panels
22	2	-	2	2	-
23	2	1	2	2	1
24	2	2	2	2	2
25	2	3	2	2	3
26	2	4	2	2	4

If you purchased ETP series panels then perform these steps first, otherwise skip this step and refer to the following section for installing the shelf panels.

All ETP panels are supplied with double sided tape to fix them in position. This tape should be stuck to the top rail. Do not stick the tape to the bottom rail closest to the castors.

FRONT AND END PANELS - ETP

1. Wipe down the trolley frame to remove any excess machine oil.
2. Peel the plastic protective coating off the panels.
3. The end panels are inserted into the trolley frame first. Below is a picture of the end panel inserted in position. The panels should slot into the frame neatly with the flanges of the panel sitting square with the trolley frame.

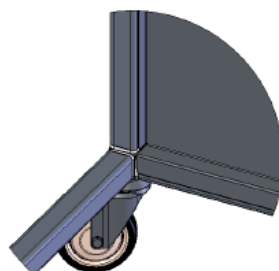

4. Insert the front panels in the same manner but do not stick them down yet.

- a. Install the smaller outer panels (300mm wide) first.
- b. If your ETP set has been supplied with additional larger panels (325mm wide) then place them in between the outer panels. These panels have been designed to have a 1mm gap on either side of each panel once installed.
- c. Before you stick them in position, arrange them so that this clearance is achieved and hold them temporarily in place with some sticky tape.
- d. Once you are happy with their positions, use the supplied double-sided tape to stick them permanently to the top rail one at a time.

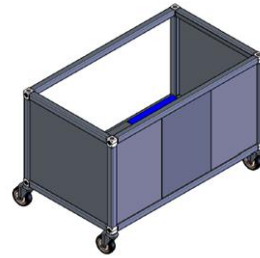
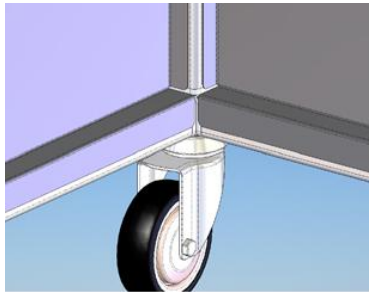

SHELF PANELS - ET

To install the shelf panels, follow these steps.

1. Wipe down the trolley frame removing any excess machine oil.
2. Peel the plastic protective coating off the shelf panels.
3. Place the smaller outer shelf panels (300mm wide) in place first. If your trolley has been supplied with additional larger shelf panels (325mm wide) then place them in between the outer panels to complete the shelf. These panels do not require any fixing, they simply lay them in position on the trolley frame. Refer to the images below.

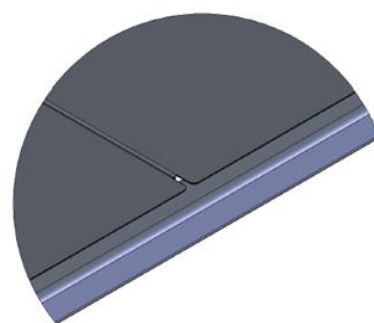
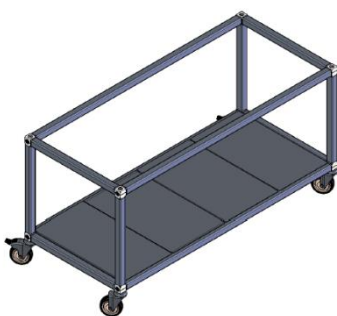

WARRANTY

The warranty conditions set out below are in addition to any warranties implied or governed by law.

Roband Australia warrants that this appliance shall be delivered free from defects in material and workmanship. The warranty for this product is offered to the original purchaser, to be free of fault in both workmanship and materials for a period of 12 months from date of purchase. Roband's obligations pursuant to this warranty are limited to the repair or replacement of the defective goods or materials, at its discretion and subject to the terms contained within this Warranty statement.

The following conditions apply:

The product must be installed, maintained and used under normal operating conditions within the scope of the operating instructions.

All warranty claims must be submitted to Roband or an authorised Roband dealer, and Roband authorisation must be granted prior to repairs being carried out. Proof of purchase is required for any repair authorisation.

Warranty is back to base, meaning delivery to and collection of your product to Roband or an authorized service agent is the responsibility of the purchaser.

Where a product cannot be returned back to base, on-site warranty can be arranged by prior agreement.

The following exclusions apply:

Claims or faults arising from misuse, neglect, transport damage or other mechanical damage, including but not limited to; door's, hinges & interlock switches etc., other than those arising from manufacture or material defects. Where relevant, glass, Teflon® and lamps are not included in this warranty and RCD tripping due to moisture absorption by Tubular Heating Elements is not a warranty fault.

Roband or any subsidiary company or Agent shall not be liable for loss of profit or damage to other equipment and property except where it is in breach of the guarantees provided in accordance with applicable legislation.

Roband reserves the right to reject a warranty claim if it is not satisfied with the circumstances under which the fault occurred or where a product has been altered from its original specification.

For on-site repairs outside of capital city metropolitan areas, travel costs, service callout fee and related labour costs etc. are the responsibility of the claimant.

Any costs incurred for false claims or faults due to incorrect usage etc. are the responsibility of the claimant.

Any attempt to repair the product by non-Roband approved service personnel or the use of non-genuine parts will void the warranty agreement

Our goods come with guarantees that cannot be excluded under the Australian Consumer Law. You are entitled to a replacement or refund for a major failure and compensation for any other reasonably foreseeable loss or damage. You are also entitled to have the goods repaired or replaced if the goods fail to be of acceptable quality and the failure does not amount to a major failure.

For the name of your nearest Australian authorised service agent, please contact:

Roband Australia Pty Ltd
1 Inman Road,
Cromer, NSW, 2099, Australia
Warranty: 1800 268 848
Tel: +61 2 9971 1788
Email: sales@roband.com.au
Web: www.roband.com.au

For your nearest International distributor,
please visit:
<https://www.roband.com.au/global/>



© Copyright 2024 – Roband® Australia Pty Ltd

All rights reserved. No part of this work may be reproduced or copied in any form or by any means, electronic or mechanical, including photocopying or posting to a website, without the written permission of the publisher. The material contained within this document is intended entirely for instructional Purposes. Roband® Australia is a wholly Australian owned company and has been manufacturing quality commercial catering equipment for the food service industry for more than 60 years.